

# LOW VOLTAGE CABLES

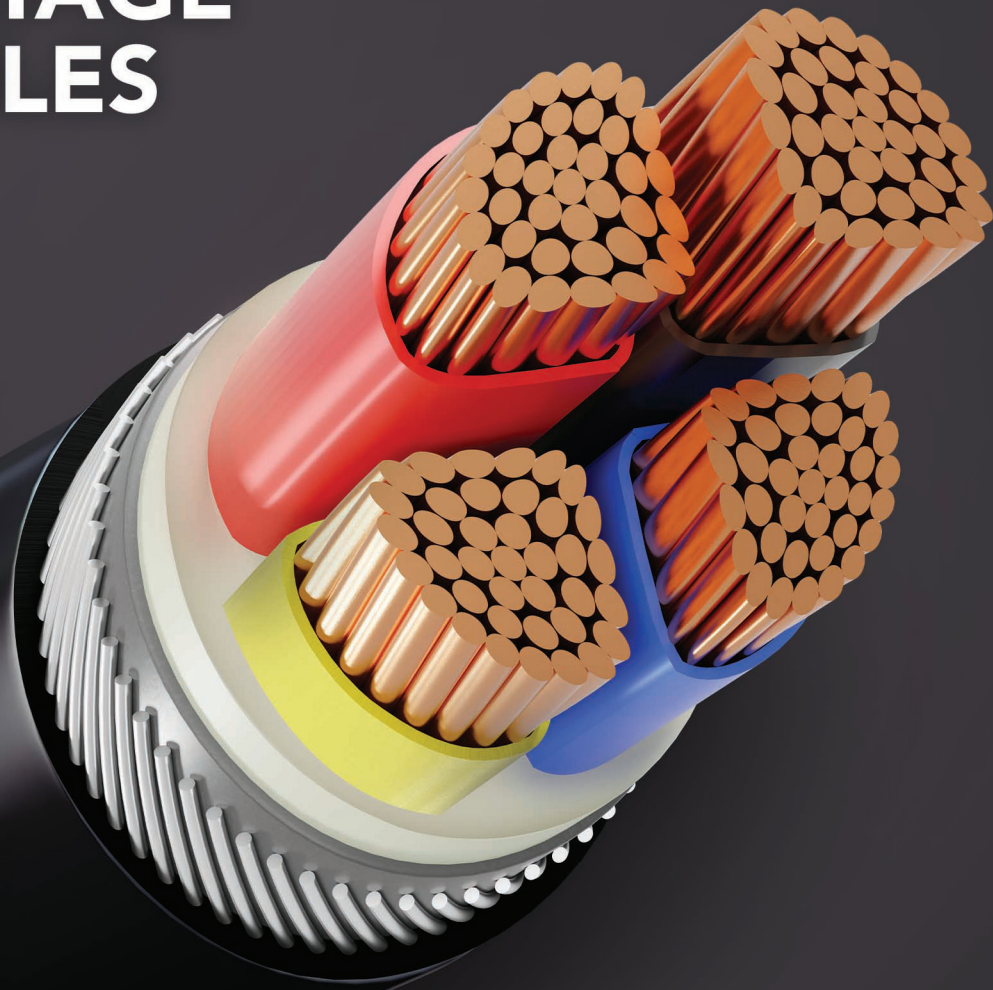



# Introduction



إحدى شركات مجموعة كابلات الرياض  
One of Riyadh Cables Group Companies

## Pioneers in Electrical Cable Production.



Al Rowad Company stands as a trailblazer in Iraq's electrical cable industry, being the first investment entity in the country dedicated to producing low and medium voltage cables. Spread across a vast 75,000 square meters in South Baghdad, Al Rowad boasts cutting-edge production lines, advanced equipment, and state-of-the-art quality testing systems. Our unwavering commitment to excellence has earned us some of the industry's most prestigious certifications, including ISO 14001, 9001, and 45001, establishing us as a leader in the Middle East.

As part of the Riyadh Cables Group's global footprint, Al Rowad shares in the group's ethos of industrial and commercial integration. From raw materials to the final product, everything is produced in-house, ensuring the highest quality and efficiency.

### Riyadh Cables Group

Founded in 1984, Riyadh Cables Group has grown into one of the largest manufacturers and exporters of electrical cables. Our commitment to international quality standards, safety, and continuous innovation has positioned us as a trusted name in the industry. The group's product range includes Low Voltage (LV), Medium Voltage (MV), High Voltage (HV), Extra High Voltage cables, overhead conductors, control cables, low smoke cables, and fire-resistant cables

### Supporting Iraq's Growth

With Iraq's rapidly expanding energy sector, the demand for high-quality cables has soared. To meet this growing need, Riyadh Cables Group has made significant investments through Al Rowad, ensuring that Iraq is equipped with the best in electrical cable technology. This investment not only meets the domestic market's needs but also creates valuable job opportunities and facilitates exports.

### Our Product Range

- Building Wires
- Specialized Wires and Cables
- Fire-Resistant Cables and Wires
- Control Cables
- Low Voltage Cables
- Medium Voltage Cables
- Overhead Conductors

**At Al Rowad, we're not just manufacturing cables; we're powering Iraq's future.**



# INTRODUCTION

This catalog contains technical information on Al-Rowad Cables' low voltage cables, including PVC and XLPE insulations with Copper/Aluminium conductors, in armoured and unarmoured designs, single-core and multicore constructions, along with a range of sheathing options. Cables are categorized by insulation and armouring. Each section provides relevant technical details and constructional data.

## PRODUCT SPECIFICATIONS

All cable designs outlined in this catalog are based on constructions covered by IEC 60502. Please note, however, that Al-Rowad Cables can also supply a range of alternative designs to meet specialized customer needs, including enhanced fire performance and added environmental protection. Cables can be supplied with alternative sheathing materials and colors or can be customized to individual customer specifications or other recognized national and international standards. In particular, cables can be manufactured to meet specific requirements for reducing smoke and toxic gases by using low-smoke and non-halogen materials.

## CABLE SELECTION

It is essential to ensure that the type of cable ordered is suitable for its intended use. Cable selection will depend on a wide range of factors, including installation specifications, relevant local regulations, and the performance characteristics of the appropriate cable types. As it is not possible to provide a conclusive guide to cable selection, we recommend contacting us for specialized advice on suitable designs to meet your specific cable needs.

## CONDUCTORS

Conductors shall be made of Copper or Aluminium, circular stranded (non-compacted or compacted) or shaped, Class 2 as per IEC 60228. For smaller sizes, solid circular conductors, Class 1 as per IEC 60228, can also be supplied upon request.

## INSULATION

XLPE material and thickness shall comply with IEC 60502 and be rated for 90°C continuous operation.

PVC material and thickness shall comply with IEC 60502, with PVC insulation material classified as Type A as per IEC 60502-1.

## ASSEMBLY

Two, three, or four insulated conductors are laid up together with non-hygroscopic fillers compatible with the insulation material, and the assembly is bedded with an extruded layer of PVC. In the case of non-armoured cables, this layer may be omitted if the outer shape of the cable remains practically circular.

## COLOUR CODE

Colour code (1) is followed by all utilities in the Middle East, and the colour of insulation is as specified below. However, cables as per colour code (2) mentioned below are also provided based on customer requests.

### Colour code (1):

- 1 Core: Red or Black
- 2 Core: Red, Black
- 3 Core: Red, Yellow, Blue
- 4 Core: Red, Yellow, Blue, Black
- 5 Core: Red, Yellow, Blue, Black, Green
- Above 5 cores: Black cores with white numerals

### Colour code (2):

- 1 Core: Brown or Blue
- 2 Core: Brown, Blue
- 3 Core: Brown, Black, Grey
- 4 Core: Blue, Brown, Black, Grey
- 5 Core: Green/Yellow, Blue, Brown, Black, Grey
- Above 5 cores: Black cores with white numerals

## ARMOUR

Galvanized steel wires are applied helically over the bedding as per IEC 60502. (Single-core cables shall be aluminium wire armoured.) Double steel tapes are applied helically over the bedding of multicore cables as per IEC 60502.

## OUTER SHEATH

The outer sheath shall be extruded PVC Type ST2 as per IEC 60502-1. Special types of PVC sheathing materials, such as fire-retardant PVC, anti-termite and anti-rodent PVC, ultraviolet-resistant PVC, oil-resistant PVC, etc., are available on request. Additionally, other special sheathing materials such as LLDPE, MDPE, HDPE, and CPE are also available.

## FIRE PERFORMANCE OF CABLE SHEATHS

Cables can be supplied with a special flame-retardant PVC outer sheath to comply with the flame-retardant test requirements of IEC 60332-3-22, IEC 60332-3-23, or IEC 60332-3-24. Al-Rowad Cables can also supply cables with low smoke halogen-free (LSHF) material of Type ST8 according to IEC 60502-1 or other equivalent standards.

## QUALITY ASSURANCE

Effective Quality Assurance procedures are essential to ensure the consistency, long-term reliability, and performance of all Al-Rowad Cables products. Al-Rowad Cables has always recognized the importance of Quality Assurance, and this commitment is reflected in the company's accreditation. At Al-Rowad Cables, Quality Assurance is an integral part of the production and supply process and is maintained at all stages, from order entry and manufacture through testing, packaging, and shipping. All Quality Assurance procedures and systems are regularly audited against international standards.



## MORE INFORMATION FOR LSHF CABLES

Fire is a complex and emotive subject; the consequences of fire can be catastrophic.

The organic materials used in the manufacture of cables and possible installation conditions in fire-prone areas can lead to situations where cables may contribute to the spread of fire, the emission of smoke, and the release of combustion products harmful to equipment and human health.

In power stations, hospitals, theatres, hotels, and other large public buildings, the loss of visibility caused by smoke from burning cable materials can cause panic and create serious challenges during evacuation. Locating the fire source and firefighting efforts are also greatly hampered by smoke. Additionally, the presence of corrosive gases in the smoke results in damage and failure of sensitive electrical equipment and may initiate long-term deterioration of structures, as well as being harmful to the health of personnel even after short exposure.

Awareness of this situation has led to the development of new cable technologies and the introduction by major cable users of cable types with low smoke emission, reduced corrosive and toxic fumes, and limited flame propagation properties.

When considering cable systems with improved fire performance characteristics, it is useful to evaluate the various aspects of fire's effect on a cable:

- Propagation of fire along cable runs
- Evolution of smoke leading to obstruction of exits
- Evolution of acid gas causing corrosion of equipment
- Evolution of toxic fumes leading to personal injury

LSHF cables use special formulations based on non-halogenated polymers to minimize smoke generation as much as possible. Materials are carefully selected, and the compounds are precisely designed to ensure the best performance of the external sheaths, which are directly exposed to fire.

LSHF cables manufactured by Al-Rowad Cables are designed to offer improved performance in areas where smoke and fume emissions during a fire would pose significant challenges. Compounds used in LSHF cables do not contain halogens and hence do not emit halogenated acids when burned. This helps minimize the total cost of damage caused by fire and generates little smoke when burned. Furthermore, the rate at which this low level of smoke is released is significantly slower than that of PVC or similar halogenated polymers.

LSHF cables manufactured by Al-Rowad Cables have controlled limits on smoke evolution, assessed by burning samples of cables in a 3-meter cube smoke chamber as per IEC 61034. Generally, these cables combine the properties of low corrosive gas emission and low toxic gas emission as they are essentially halogen-free, as assessed by IEC 60754-1 and IEC 60754-2.

## MORE INFORMATION FOR LSHF CABLES BUNCH BURNING TEST (IEC 60332-3 SERIES)

### MORE INFORMATION FOR LSHF CABLES SMOKE DENSITY 3M TEST CUBE (IEC 61034) PURPOSE

The measurement of smoke density is an important aspect of evaluating the burning performance of electric cables, as it is related to the evacuation of individuals and accessibility for firefighting. The standard describes the measurement of smoke emission when electric cables are burned horizontally. The light transmittance under flaming and smouldering conditions can be used to compare different cables.

### EQUIPMENT

1. Cube enclosure
2. Photometric system
3. Fire source
4. Smoke mixer

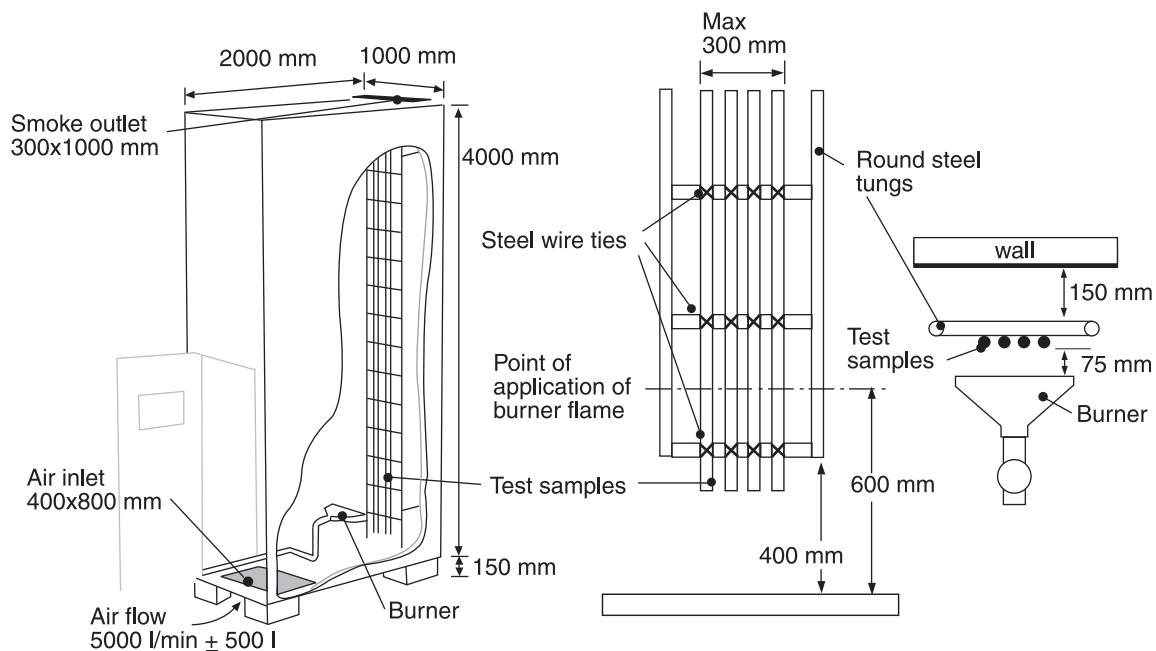

### PURPOSE

This standard describes a method for type approval testing to determine the ability of bunched cables to restrain flame propagation under defined conditions, regardless of their application (e.g., power, telecommunications, data transmission, or optical fibre cables).

Three categories (A, B, and C) are defined, distinguished by test duration and the volume of non-metallic material in the sample under test. Two methods of mounting (designations F/R and F) apply to category A. Only designation F applies to categories B and C.

### EQUIPMENT

1. Fire test rig
2. Ladder
3. Ignition source



## MORE INFORMATION FOR LSHF CABLES

### SMOKE DENSITY 3M TEST CUBE (IEC 61034)

#### PURPOSE

The measurement of smoke density is an important aspect of evaluating the burning performance of electric cables, as it is related to the evacuation of individuals and accessibility for firefighting. The standard describes the measurement of smoke emission when electric cables are burned horizontally. The light transmittance under flaming and smouldering conditions can be used to compare different cables.

#### EQUIPMENT

1. Cube enclosure
2. Photometric system
3. Fire source
4. Smoke mixer

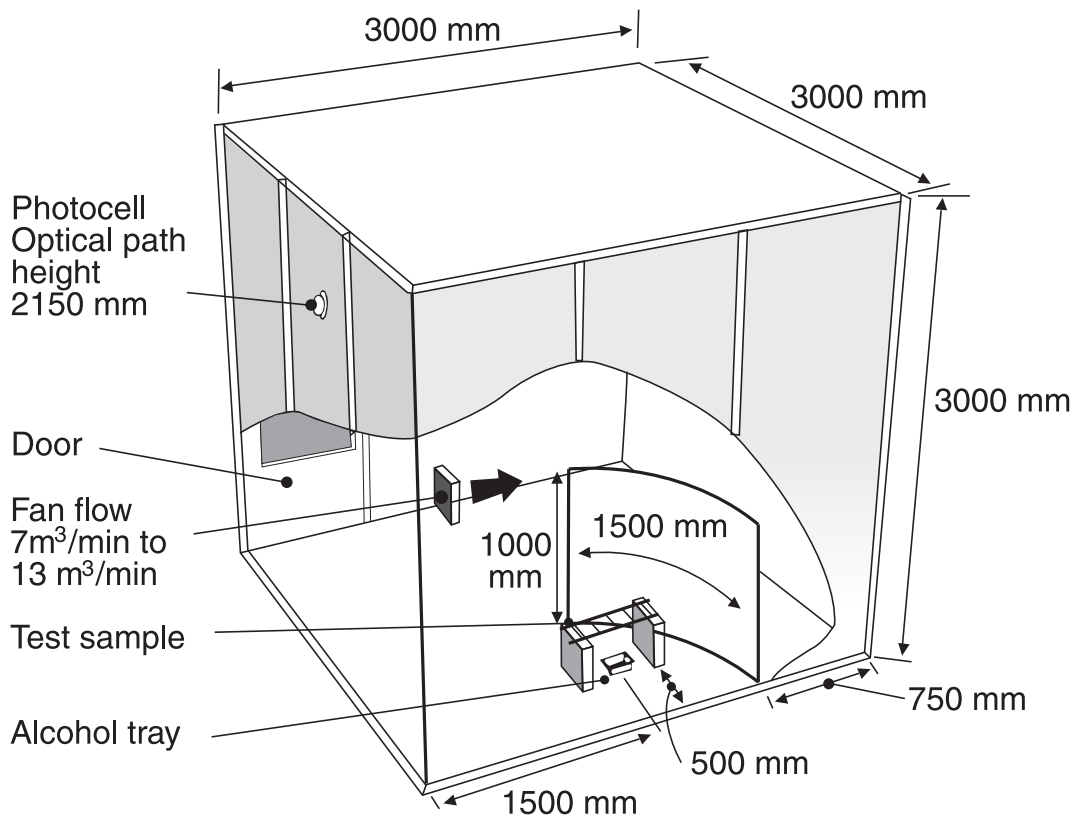

## MORE INFORMATION FOR LSHF CABLES ACIDITY (pH) AND CONDUCTIVITY (IEC 60754-2)

### TEST ON GASES EVOLVED DURING COMBUSTION OF ELECTRIC CABLES

#### PURPOSE

The purpose of this test is to determine the pH and conductivity of gases evolved during the combustion of materials taken from electric cables as a function of temperature.

#### PRINCIPLE OF OPERATION

A predetermined quantity of the test material is burned in a tube furnace. The evolved gases are trapped by bubbling through bottles filled with distilled or demineralized water. The acidity is measured by determining the pH value. The conductivity of the solution is also measured.

#### EQUIPMENT

1. Test apparatus
2. pH meter
3. Conductivity meter
4. Analytical balance
5. Computer with a measuring program
6. Deionized water

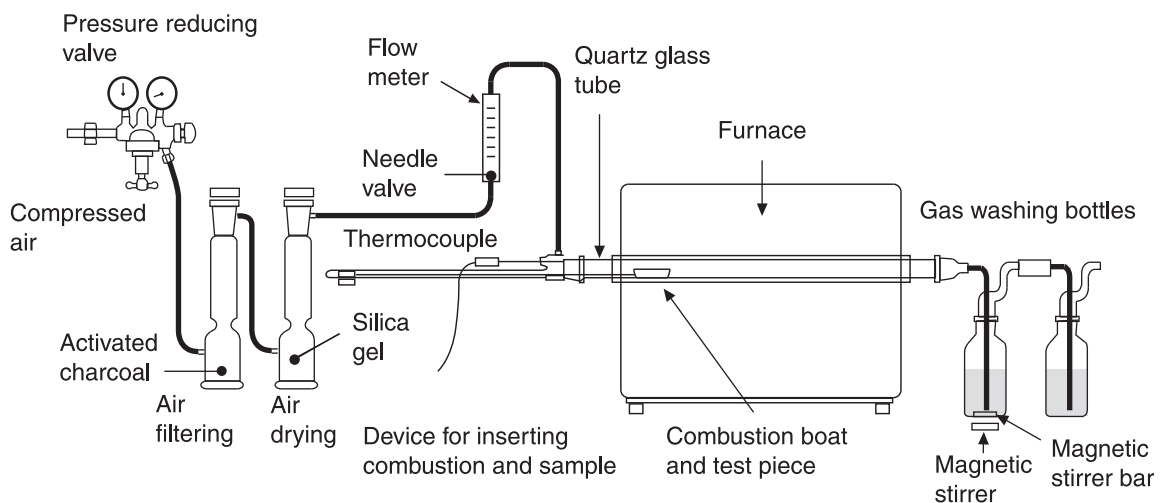

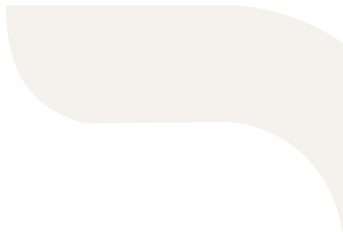

## Single Core - Copper Conductor, XLPE Insulated Cables

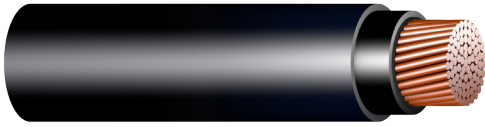

Conductor : Round Stranded Copper  
 Insulation : Extruded XLPE Material  
 Oversheath : Extruded Material (PVC, LSF or PE)

1- Core CU/XLPE/Sheathed 600/1000 V Cables as per IEC 60502-1						
Nominal Area	Number of Strands	Approx Conductor Diameter	Nominal Insulation Thickness	Nominal Outer Sheath Thickness	Approx. Overall Diameter*	Approx. Cable Weight
mm	No.	mm	mm	mm	mm	kg/km
1 x 1.5	7	1.6	0.7	1.4	6	50
1 x 2.5	7	2.0	0.7	1.4	7	70
1 x 4	7	2.6	0.7	1.4	7	80
1 x 6	7	3.1	0.7	1.4	8	110
1 x 10	7	4.0	0.7	1.4	9	150
1 x 16	7	5.0	0.7	1.4	10	210
1 x 25	7	6.3	0.9	1.4	11	310
1 x 35	7	7.4	0.9	1.4	13	410
1 x 50	19	8.8	1.0	1.4	14	530
1 x 70	19	10.6	1.1	1.4	16	740
1 x 95	19	12.4	1.1	1.5	18	1000
1 x 120	37	14.0	1.2	1.5	20	1240
1 x 150	37	15.5	1.4	1.6	22	1520
1 x 185	37	17.4	1.6	1.6	24	1890
1 x 240	61	20.3	1.7	1.7	28	2460
1 x 300	61	22.7	1.8	1.8	30	3060
1 x 400	61	25.4	2.0	1.9	34	3910
1 x 500	61	28.8	2.2	2.0	38	4980
1 x 630	61	30.4	2.4	2.2	40	6260
1 x 800	61	33.7	2.6	2.3	44	7950

\*Overall Diameter Tolerance Range: [-2% , +6%]

Continuous Current Rating									
Nominal Area	Trefoil [Gd]	Trefoil in One Duct [Gd]	Trefoil in Three Ducts [Gd]	Flat Touching [Gd]	Flat Spaced [Gd]	Flat Spaced in Three Ducts [Gd]	Trefoil [Air]	Flat Spaced [Air]	Flat Touching [Air]
mm	Amps	Amps	Amps	Amps	Amps	Amps	Amps	Amps	Amps
1 x 1.5	22	21	21	22	24	21	18	25	19
1 x 2.5	29	27	29	29	31	27	25	34	26
1 x 4	38	34	37	37	39	35	32	44	33
1 x 6	47	43	45	47	49	44	42	56	43
1 x 10	62	57	59	61	65	57	58	77	59
1 x 16	80	73	77	79	83	75	76	101	79
1 x 25	102	94	98	100	106	95	100	133	103
1 x 35	122	113	119	120	128	115	127	166	131
1 x 50	144	134	139	142	150	135	153	200	157
1 x 70	176	164	172	173	184	167	195	254	201
1 x 95	211	197	204	206	220	199	241	313	248
1 x 120	240	225	234	234	251	228	282	365	291
1 x 150	268	253	261	262	281	256	325	418	335
1 x 185	302	286	297	295	318	291	375	482	387
1 x 240	351	333	347	341	371	341	455	583	470
1 x 300	392	373	393	381	417	385	517	667	535
1 x 400	443	423	448	430	476	441	605	781	625
1 x 500	496	475	515	481	541	505	697	909	721
1 x 630	547	525	574	530	606	566	777	1025	804
1 x 800	599	576	639	580	676	633	873	1167	903

- When cables are arranged in spaced formation they are spaced by one cable diameter.



## Multicore (Two & Three Cores) - Copper Conductor, XLPE Insulated Cables

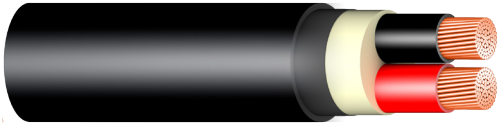

Conductor : Round Stranded Copper  
 Insulation : Extruded XLPE Material  
 Oversheath : Extruded Material (PVC, LSF or PE)

2-Cores CU/XLPE/Sheathed 600/1000 V Cables as per IEC 60502-1							Continuous Current Rating		
Nominal Area	Number of Strands	Approx Conductor Diameter	Nominal Insulation Thickness	Nominal Outer Sheath Thickness	Approx. Overall Diameter*	Approx. Cable Weight	Ground	Duct [Gd]	Free Air
							Amps	Amps	Amps
mm	No.	mm	mm	mm	mm	kg/km			
2 x 1.5	7	1.6	0.7	1.8	13	190	22	21	21
2 x 2.5	7	2.0	0.7	1.8	13	240	29	27	29
2 x 4	7	2.6	0.7	1.8	14	290	38	34	37
2 x 6	7	3.1	0.7	1.8	16	350	47	43	45
2 x 10	7	4.0	0.7	1.8	17	480	62	57	59
2 x 16	7	5.0	0.7	1.8	19	650	80	73	77
2 x 25	7	6.3	0.9	1.8	23	930	102	94	98
2 x 35	7	7.4	0.9	1.8	25	1190	122	113	119
2 x 50	19	8.8	1.0	1.8	28	1540	144	134	139
2 x 70	19	10.6	1.1	1.8	32	2100	176	164	172
2 x 95	19	12.4	1.1	2.0	37	2830	211	197	204
2 x 120	37	14.0	1.2	2.1	40	3500	240	225	234
2 x 150	37	15.5	1.4	2.2	44	4260	268	253	261
2 x 185	37	17.4	1.6	2.3	50	5340	302	286	297
2 x 240	61	20.3	1.7	2.5	56	6900	351	333	347
2 x 300	61	22.7	1.8	2.7	62	8600	392	373	393
2 x 400	61	25.4	2.0	2.9	69	10830	443	423	448
2 x 500	61	28.8	2.2	3.1	77	13710	496	475	515

\*Overall Diameter Tolerance Range: [-2% , +6%]

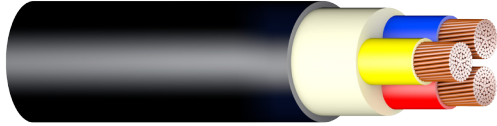

Conductor : Round Stranded Copper  
 Insulation : Extruded XLPE Material  
 Oversheath : Extruded Material (PVC, LSF or PE)

3-Cores CU/XLPE/Sheathed 600/1000 V Cables as per IEC 60502-1							Continuous Current Rating		
Nominal Area	Number of Strands	Approx Conductor Diameter	Nominal Insulation Thickness	Nominal Outer Sheath Thickness	Approx. Overall Diameter*	Approx. Cable Weight	Ground	Duct [Gd]	Free Air
							Amps	Amps	Amps
mm	No.	mm	mm	mm	mm	kg/km			
3 x 1.5	7	1.6	0.7	1.8	13	210	21	17	18
3 x 2.5	7	2.0	0.7	1.8	14	260	27	23	24
3 x 4	7	2.6	0.7	1.8	15	330	35	29	31
3 x 6	7	3.1	0.7	1.8	16	410	44	37	39
3 x 10	7	4.0	0.7	1.8	18	570	58	49	54
3 x 16	7	5.0	0.7	1.8	20	790	75	63	71
3 x 25	7	6.3	0.9	1.8	24	1160	98	82	96
3 x 35	7	7.4	0.9	1.8	27	1380	115	99	115
3 x 50	19	8.8	1.0	1.8	30	1790	137	118	140
3 x 70	19	10.6	1.1	1.9	35	2510	167	146	176
3 x 95	19	12.4	1.1	2.0	39	3350	200	176	216
3 x 120	37	14.0	1.2	2.1	43	4150	227	201	251
3 x 150	37	15.5	1.4	2.3	48	5120	254	227	285
3 x 185	37	17.4	1.6	2.4	53	6360	286	257	327
3 x 240	61	20.3	1.7	2.6	60	8280	330	299	386
3 x 300	61	22.7	1.8	2.8	67	10270	370	339	441
3 x 400	61	25.4	2.0	3.1	74	13040	414	383	502
3 x 500	61	28.8	2.2	3.3	83	16610	462	431	569

\*Overall Diameter Tolerance Range: [-2% , +6%]

## Multicore (Three and half & Four Cores) - Copper Conductor, XLPE Insulated Cables

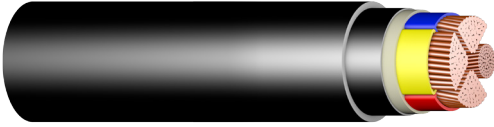

Conductor : Round / Sectoral Stranded Copper  
 Insulation : Extruded XLPE Material  
 Oversheath : Extruded Material (PVC, LSF or PE)

3½-Cores CU/XLPE/Sheathed 600/1000 V Cables as per IEC 60502-1							Continuous Current Rating		
Nominal Area*	Number of Strands	Approx Conductor Diameter	Nominal Insulation Thickness	Nominal Outer Sheath Thickness	Approx. Overall Diameter**	Approx. Cable Weight	Ground	Duct [Gd]	Free Air
							Amps	Amps	Amps
mm	No.	mm	mm	mm	mm	kg/km			
3x16+10	7 / 7	5 / 4	0.7 / 0.7	1.8	22	900	76	64	73
3x25+16	7 / 7	6.3 / 5	0.9 / 0.7	1.8	25	1320	98	83	97
3x35+16	7 / 7	6.6 / 5	0.9 / 0.7	1.8	25	1470	114	97	112
3x50+25	19 / 7	7.5 / 6.3	1.0 / 0.9	1.8	29	1950	135	117	137
3x70+35	19 / 7	9.1 / 7.4	1.1 / 0.9	1.9	33	2740	165	143	172
3x95+50	19 / 19	11 / 8.8	1.1 / 1.0	2.1	37	3670	198	173	211
3x120+70	37 / 19	12.2 / 10.6	1.2 / 1.1	2.2	41	4620	225	197	244
3x150+70	37 / 19	13.8 / 10.6	1.4 / 1.1	2.3	45	5580	251	224	278
3x185+95	37 / 19	15.1 / 12.4	1.6 / 1.1	2.5	50	7000	283	253	318
3x240+120	61 / 37	17.6 / 14	1.7 / 1.2	2.7	55	9040	326	294	373
3x300+150	61 / 37	19.8 / 15.5	1.8 / 1.4	2.9	61	11180	366	333	426
3x400+185	61 / 37	22.2 / 17.4	2.0 / 1.6	3.1	68	14160	412	379	490
3x500+240	61 / 61	26.3 / 20.3	2.2 / 1.7	3.4	76	18070	462	428	558

\*Sectoral Shape for conductor size > 25 mm<sup>2</sup>

\*\*Overall Diameter Tolerance Range: [-2% , +6%]

[Ph]: Phase [Ne]: Neutral



Conductor : Round / Sectoral Stranded Copper  
 Insulation : Extruded XLPE Material  
 Oversheath : Extruded Material (PVC, LSF or PE)

4-Cores CU/XLPE/Sheathed 600/1000 V Cables as per IEC 60502-1							Continuous Current Rating		
Nominal Area*	Number of Strands	Approx Conductor Diameter	Nominal Insulation Thickness	Nominal Outer Sheath Thickness	Approx. Overall Diameter**	Approx. Cable Weight	Ground	Duct [Gd]	Free Air
							Amps	Amps	Amps
mm	No.	mm	mm	mm	mm	kg/km			
4 x 1.5	7	1.6	0.7	1.8	14	240	21	18	18
4 x 2.5	7	2.0	0.7	1.8	15	310	28	23	24
4 x 4	7	2.6	0.7	1.8	16	390	36	30	32
4 x 6	7	3.1	0.7	1.8	18	500	45	37	41
4 x 10	7	4.0	0.7	1.8	20	700	59	50	56
4 x 16	7	5.0	0.7	1.8	22	980	77	64	74
4 x 25	7	6.3	0.9	1.8	26	1450	99	84	99
4 x 35	7	6.6	0.9	1.8	26	1650	115	98	114
4 x 50	19	7.5	1.0	1.9	30	2160	136	117	139
4 x 70	19	9.1	1.1	2.0	34	3060	166	144	173
4 x 95	19	11.0	1.1	2.1	38	4100	199	175	213
4 x 120	37	12.2	1.2	2.3	43	5130	225	199	247
4 x 150	37	13.8	1.4	2.4	47	6320	253	225	281
4 x 185	37	15.1	1.6	2.6	52	7830	284	256	322
4 x 240	61	17.6	1.7	2.8	58	10180	328	298	378
4 x 300	61	19.8	1.8	3.0	64	12610	368	337	433
4 x 400	61	22.2	2.0	3.3	73	16120	415	384	497
4 x 500	61	26.3	2.2	3.5	80	20380	465	433	566

\*Sectoral Shape for conductor size > 25 mm<sup>2</sup>

\*\*Overall Diameter Tolerance Range: [-2% , +6%]



## Multicore (Five Cores) - Copper Conductor, XLPE Insulated Cables

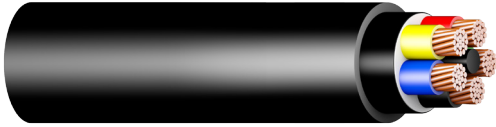

Conductor : Round Stranded Copper  
 Insulation : Extruded XLPE Material  
 Oversheath : Extruded Material (PVC, LSF or PE)

5-Cores CU/XLPE/Sheathed 600/1000 V Cables as per IEC 60502-1							Continuous Current Rating		
Nominal Area	Number of Strands	Approx Conductor Diameter	Nominal Insulation Thickness	Nominal Outer Sheath Thickness	Approx. Overall Diameter*	Approx. Cable Weight	Ground	Duct [Gd]	Free Air
							Amps	Amps	Amps
mm	No.	mm	mm	mm	mm	kg/km			
5 x 1.5	7	1.6	0.7	1.8	15	280	21	18	19
5 x 2.5	7	2.0	0.7	1.8	16	360	28	23	25
5 x 4	7	2.6	0.7	1.8	17	460	36	30	33
5 x 6	7	3.1	0.7	1.8	19	590	45	38	42
5 x 10	7	4.0	0.7	1.8	21	840	60	50	57
5 x 16	7	5.0	0.7	1.8	24	1190	78	66	76
5 x 25	7	6.3	0.9	1.8	28	1770	100	85	102
5 x 35	7	7.4	0.9	1.8	32	2180	120	104	126
5 x 50	19	8.8	1.0	2.0	37	2920	142	124	154
5 x 70	19	10.6	1.1	2.1	42	4050	174	153	194
5 x 95	19	12.4	1.1	2.3	48	5510	208	186	238
5 x 120	37	14.0	1.2	2.4	53	6850	237	212	277
5 x 150	37	15.5	1.4	2.6	58	8380	265	239	315
5 x 185	37	17.4	1.6	2.8	65	10520	299	272	362
5 x 240	61	20.3	1.7	3.0	74	13620	346	318	431
5 x 300	61	22.7	1.8	3.2	82	16990	387	359	491
5 x 400	61	25.4	2.0	3.6	91	21640	434	406	560
5 x 500	61	28.8	2.2	3.8	102	27450	486	459	639

\*Overall Diameter Tolerance Range: [-2% , +6%]

## Single Core - Aluminium Conductor, XLPE Insulated Cables



Conductor : Round Stranded Aluminium  
 Insulation : Extruded XLPE Material  
 Oversheath : Extruded Material (PVC, LSF or PE)

**1- Core AL/XLPE/Sheathed 600/1000 V Cables as per IEC 60502-1**

Nominal Area	Number of Strands	Approx Conductor Diameter	Nominal Insulation Thickness	Nominal Outer Sheath Thickness	Approx. Overall Diameter*	Approx. Cable Weight
mm	No.	mm	mm	mm	mm	kg/km
1 x 10	7	3.9	0.7	1.4	9	90
1 x 16	7	4.7	0.7	1.4	9	110
1 x 25	7	6.3	0.9	1.4	11	160
1 x 35	7	7.4	0.9	1.4	13	200
1 x 50	19	8.8	1.0	1.4	14	250
1 x 70	19	10.6	1.1	1.4	16	330
1 x 95	19	12.4	1.1	1.5	18	430
1 x 120	37	14.0	1.2	1.5	20	530
1 x 150	37	15.5	1.4	1.6	22	640
1 x 185	37	17.4	1.6	1.6	24	780
1 x 240	61	19.9	1.7	1.7	27	990
1 x 300	61	22.2	1.8	1.8	30	1210
1 x 400	61	25.2	2.0	1.9	33	1530
1 x 500	61	28.6	2.2	2.0	38	1910
1 x 630	91	32.6	2.4	2.2	42	2470
1 x 800	91	36.7	2.6	2.3	47	3090

\*Overall Diameter Tolerance Range: [-2% , +6%]

**Continuous Current Rating**

Nominal Area	Trefoil [Gd]	Trefoil in One Duct [Gd]	Trefoil in Three Ducts [Gd]	Flat Touching [Gd]	Flat Spaced [Gd]	Flat Spaced in Three Ducts [Gd]	Trefoil [Air]	Flat Spaced [Air]	Flat Touching [Air]
mm	Amps	Amps	Amps	Amps	Amps	Amps	Amps	Amps	Amps
1 x 10	48	44	45	47	50	44	44	59	45
1 x 16	61	56	58	60	64	56	57	76	58
1 x 25	79	73	76	78	82	74	78	103	80
1 x 35	95	88	92	93	99	89	98	129	101
1 x 50	112	104	108	110	117	105	118	155	122
1 x 70	137	128	133	134	143	129	151	197	156
1 x 95	164	153	158	160	171	154	187	242	193
1 x 120	186	175	182	182	195	177	220	284	227
1 x 150	209	197	202	204	218	199	253	324	261
1 x 185	237	223	231	230	247	226	293	375	303
1 x 240	274	260	270	267	288	264	352	448	363
1 x 300	310	295	307	301	326	301	409	520	423
1 x 400	354	338	353	344	373	346	479	609	496
1 x 500	406	388	410	393	430	402	570	723	589
1 x 630	460	441	468	445	492	461	663	844	686
1 x 800	517	497	531	499	559	525	767	982	794

- When cables are arranged in spaced at formation they are spaced by one cable diameter.



## Multicore (Two & Three Cores) - Aluminium Conductor, XLPE Insulated Cables



Conductor : Round Stranded Aluminium  
 Insulation : Extruded XLPE Material  
 Oversheath : Extruded Material (PVC, LSF or PE)

2-Cores AL/XLPE/Sheathed 600/1000 V Cables as per IEC 60502-1							Continuous Current Rating		
Nominal Area	Number of Strands	Approx Conductor Diameter	Nominal Insulation Thickness	Nominal Outer Sheath Thickness	Approx. Overall Diameter*	Approx. Cable Weight	Ground	Duct [Gd]	Free Air
							Amps	Amps	Amps
mm	No.	mm	mm	mm	mm	kg/km			
2 x 10	7	3.9	0.7	1.8	17	340	53	45	48
2 x 16	7	4.7	0.7	1.8	18	420	69	58	63
2 x 25	7	6.3	0.9	1.8	22	610	90	76	86
2 x 35	7	7.4	0.9	1.8	25	750	108	92	106
2 x 50	19	8.8	1.0	1.8	28	950	128	110	129
2 x 70	19	10.6	1.1	1.8	32	1260	157	137	164
2 x 95	19	12.4	1.1	2.0	36	1670	188	164	200
2 x 120	37	14.0	1.2	2.1	40	2040	214	188	233
2 x 150	37	15.5	1.4	2.2	44	2460	240	212	266
2 x 185	37	17.4	1.6	2.3	49	3080	272	243	306
2 x 240	61	19.9	1.7	2.5	55	3870	316	285	364
2 x 300	61	22.2	1.8	2.7	61	4770	356	325	418
2 x 400	61	25.2	2.0	2.9	68	5980	408	374	488
2 x 500	61	28.6	2.2	3.1	76	7450	466	432	568

\*Overall Diameter Tolerance Range: [-2% , +6%]



Conductor : Round Stranded Aluminium  
 Insulation : Extruded XLPE Material  
 Oversheath : Extruded Material (PVC, LSF or PE)

3-Cores AL/XLPE/Sheathed 600/1000 V Cables as per IEC 60502-1							Continuous Current Rating		
Nominal Area	Number of Strands	Approx Conductor Diameter	Nominal Insulation Thickness	Nominal Outer Sheath Thickness	Approx. Overall Diameter*	Approx. Cable Weight	Ground	Duct [Gd]	Free Air
							Amps	Amps	Amps
mm	No.	mm	mm	mm	mm	kg/km			
3 x 10	7	3.9	0.7	1.8	18	380	45	37	41
3 x 16	7	4.7	0.7	1.8	19	470	58	49	54
3 x 25	7	6.3	0.9	1.8	24	690	76	64	74
3 x 35	7	7.4	0.9	1.8	26	750	89	76	88
3 x 50	19	8.8	1.0	1.8	30	940	106	91	108
3 x 70	19	10.6	1.1	1.9	35	1290	130	113	137
3 x 95	19	12.4	1.1	2.0	39	1640	155	136	168
3 x 120	37	14.0	1.2	2.1	43	1990	177	156	195
3 x 150	37	15.5	1.4	2.3	48	2460	198	177	222
3 x 185	37	17.4	1.6	2.4	53	3020	224	201	256
3 x 240	61	19.9	1.7	2.6	60	3850	260	236	304
3 x 300	61	22.2	1.8	2.8	66	4670	293	268	349
3 x 400	61	25.2	2.0	3.1	73	5870	335	310	405
3 x 500	61	28.6	2.2	3.3	83	7350	382	356	470

\*Overall Diameter Tolerance Range: [-2% , +6%]

## Multicore (Three and half & Four Cores) - Aluminium Conductor, XLPE Insulated Cables

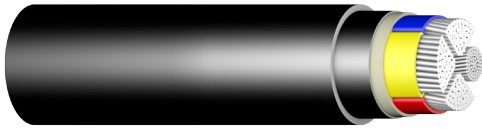

Conductor : Round / Sectoral Stranded Aluminium  
 Insulation : Extruded XLPE Material  
 Oversheath : Extruded Material (PVC, LSF or PE)

3 1/2 -Cores AL/XLPE/Sheathed 600/1000 V Cables as per IEC 60502-1							Continuous Current Rating		
Nominal Area*	Number of Strands	Approx Conductor Diameter	Nominal Insulation Thickness	Nominal Outer Sheath Thickness	Approx. Overall Diameter**	Approx. Cable Weight	Ground	Duct [Gd]	Free Air
							Amps	Amps	Amps
mm	No.	mm	mm	mm	mm	kg/km			
3x16+10	7 / 7	4.7 / 3.9	0.7 / 0.7	1.8	20	530	58	49	55
3x25+16	7 / 7	6.3 / 4.7	0.9 / 0.7	1.8	24	760	76	64	75
3x35+16	7 / 7	6.5 / 4.7	0.9 / 0.7	1.8	25	740	88	75	87
3x50+25	7 / 7	7.5 / 6.3	1.0 / 0.9	1.8	29	950	105	91	106
3x70+35	14 / 7	9.1 / 7.4	1.1 / 0.9	1.9	33	1280	128	111	133
3x95+50	19 / 19	10.8 / 8.8	1.1 / 1.0	2.1	37	1650	153	134	163
3x120+70	19 / 19	12.2 / 10.6	1.2 / 1.1	2.2	41	2020	175	154	190
3x150+70	37 / 19	13.5 / 10.6	1.4 / 1.1	2.3	45	2450	195	174	216
3x185+95	37 / 19	15.2 / 12.4	1.6 / 1.1	2.5	50	3030	221	198	249
3x240+120	37 / 37	17.5 / 14	1.7 / 1.2	2.7	55	3870	256	231	293
3x300+150	37 / 37	19.6 / 15.5	1.8 / 1.4	2.9	61	4680	289	264	337
3x400+185	61 / 37	22.5 / 17.4	2.0 / 1.6	3.1	68	5890	331	304	394
3x500+240	61 / 61	25.6 / 19.9	2.2 / 1.7	3.4	76	7440	377	350	456

\*Sectoral Shape for conductor size > 25 mm<sup>2</sup>

\*\*Overall Diameter Tolerance Range: [-2% , +6%]

[Ph]: Phase [Ne]: Neutral

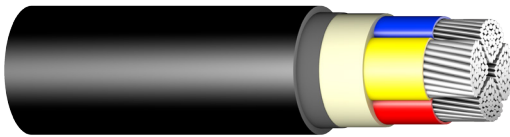

Conductor : Round / Sectoral Stranded Aluminium  
 Insulation : Extruded XLPE Material  
 Oversheath : Extruded Material (PVC, LSF or PE)

4-Cores AL/XLPE/Sheathed 600/1000 V Cables as per IEC 60502-1							Continuous Current Rating		
Nominal Area*	Number of Strands	Approx Conductor Diameter	Nominal Insulation Thickness	Nominal Outer Sheath Thickness	Approx. Overall Diameter**	Approx. Cable Weight	Ground	Duct [Gd]	Free Air
							Amps	Amps	Amps
mm	No.	mm	mm	mm	mm	kg/km			
4 x 10	7	3.9	0.7	1.8	19	440	45	38	42
4 x 16	7	4.7	0.7	1.8	21	560	59	49	56
4 x 25	7	6.3	0.9	1.8	26	840	77	65	77
4 x 35	7	6.5	0.9	1.8	26	800	89	76	88
4 x 50	7	7.5	1.0	1.9	30	1020	105	91	108
4 x 70	14	9.1	1.1	2.0	34	1390	129	112	135
4 x 95	19	10.8	1.1	2.1	38	1780	154	136	165
4 x 120	19	12.2	1.2	2.3	43	2220	175	155	192
4 x 150	37	13.5	1.4	2.4	47	2690	196	175	219
4 x 185	37	15.2	1.6	2.6	52	3310	223	200	252
4 x 240	37	17.5	1.7	2.8	58	4240	258	234	298
4 x 300	37	19.6	1.8	3.0	64	5130	291	267	342
4 x 400	61	22.5	2.0	3.3	73	6580	334	309	400
4 x 500	61	25.6	2.2	3.5	80	8160	380	354	463

\*Sectoral Shape for conductor size > 25 mm<sup>2</sup>

\*\*Overall Diameter Tolerance Range: [-2% , +6%]



## Multicore (Five Cores) - Aluminium Conductor, XLPE Insulated Cables

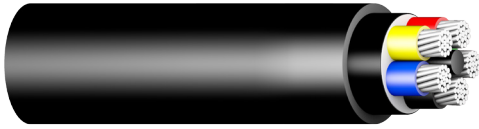

Conductor : Round Stranded Aluminium  
 Insulation : Extruded XLPE Material  
 Oversheath : Extruded Material (PVC, LSF or PE)

5-Cores AL/XLPE/Sheathed 600/1000 V Cables as per IEC 60502-1							Continuous Current Rating		
Nominal Area	Number of Strands	Approx Conductor Diameter	Nominal Insulation Thickness	Nominal Outer Sheath Thickness	Approx. Overall Diameter*	Approx. Cable Weight	Ground	Duct [Gd]	Free Air
							Amps	Amps	Amps
mm	No.	mm	mm	mm	mm	kg/km			
5 x 10	7	3.9	0.7	1.8	20	520	46	38	43
5 x 16	7	4.7	0.7	1.8	23	670	60	50	58
5 x 25	7	6.3	0.9	1.8	28	1010	78	66	79
5 x 35	7	7.4	0.9	1.8	31	1130	93	80	97
5 x 50	19	8.8	1.0	2.0	36	1500	110	96	118
5 x 70	19	10.6	1.1	2.1	42	2020	135	119	151
5 x 95	19	12.4	1.1	2.3	48	2670	162	144	185
5 x 120	37	14.0	1.2	2.4	53	3250	184	165	216
5 x 150	37	15.5	1.4	2.6	58	3950	206	187	246
5 x 185	37	17.4	1.6	2.8	65	4950	234	213	284
5 x 240	61	19.9	1.7	3.0	73	6230	272	251	338
5 x 300	61	22.2	1.8	3.2	81	7660	307	285	388
5 x 400	61	25.2	2.0	3.6	91	9690	352	329	453
5 x 500	61	28.6	2.2	3.8	101	12010	401	378	526

\*Overall Diameter Tolerance Range: [-2% , +6%]

## Single Core - Copper Conductor, PVC Insulated Cables

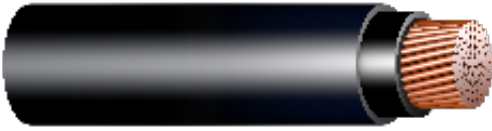

Conductor : Round Stranded Copper  
 Insulation : Extruded PVC Material  
 Oversheath : Extruded Material (PVC or PE)

**1-Core CU/PVC/Sheathed 600/1000 V Cables as per IEC 60502-1**

Nominal Area	Number of Strands	Approx Conductor Diameter	Nominal Insulation Thickness	Nominal Outer Sheath Thickness	Approx. Overall Diameter*	Approx. Cable Weight
mm	No.	mm	mm	mm	mm	kg/km
1 x 1.5	7	1.6	0.8	1.4	6	60
1 x 2.5	7	2.0	0.8	1.4	7	70
1 x 4	7	2.6	1.0	1.4	8	100
1 x 6	7	3.1	1.0	1.4	8	120
1 x 10	7	4.0	1.0	1.4	9	170
1 x 16	7	5.0	1.0	1.4	10	230
1 x 25	7	6.3	1.2	1.4	12	340
1 x 35	7	7.4	1.2	1.4	13	440
1 x 50	19	8.8	1.4	1.4	15	580
1 x 70	19	10.6	1.4	1.4	17	790
1 x 95	19	12.4	1.6	1.5	19	1080
1 x 120	37	14.0	1.6	1.5	21	1320
1 x 150	37	15.5	1.8	1.6	23	1610
1 x 185	37	17.4	2.0	1.7	25	2010
1 x 240	61	20.3	2.2	1.8	29	2620
1 x 300	61	22.7	2.4	1.9	32	3260
1 x 400	61	25.4	2.6	2.0	35	4140
1 x 500	61	28.8	2.8	2.1	39	5260
1 x 630	61	30.4	2.8	2.2	41	6470
1 x 800	61	33.7	2.8	2.3	44	8160

\*Overall Diameter Tolerance Range: [-2% , +6%]

**Continuous Current Rating**

Nominal Area	Trefoil [Gd]	Trefoil in One Duct [Gd]	Trefoil in Three Ducts [Gd]	Flat Touching [Gd]	Flat Spaced [Gd]	Flat Spaced in Three Ducts [Gd]	Trefoil [Air]	Flat Spaced [Air]	Flat Touching [Air]
mm	Amps	Amps	Amps	Amps	Amps	Amps	Amps	Amps	Amps
1 x 1.5	18	16	17	18	19	16	11	15	12
1 x 2.5	23	21	23	23	24	22	15	21	16
1 x 4	30	28	29	30	31	28	21	27	21
1 x 6	37	34	36	37	39	34	25	34	26
1 x 10	49	45	47	49	51	46	35	47	36
1 x 16	63	58	61	62	66	59	46	62	48
1 x 25	81	75	78	80	85	76	63	83	65
1 x 35	97	90	94	95	101	91	77	101	79
1 x 50	115	107	111	113	120	108	95	123	98
1 x 70	141	132	137	138	147	133	121	156	124
1 x 95	168	158	164	164	175	160	149	191	153
1 x 120	191	180	186	187	200	182	174	224	180
1 x 150	214	202	210	209	224	205	200	256	206
1 x 185	241	228	236	235	253	232	230	294	237
1 x 240	279	265	279	271	295	273	277	354	286
1 x 300	313	298	316	304	333	309	319	408	330
1 x 400	351	336	359	341	378	352	367	472	379
1 x 500	392	376	407	380	428	401	422	548	436
1 x 630	433	416	453	420	480	449	472	621	488
1 x 800	471	453	504	456	533	500	524	703	542

- When cables are arranged in spaced formation they are spaced by one cable diameter.



## Multicore (Two & Three Cores) - Copper Conductor, PVC Insulated Cables



Conductor : Round Stranded Copper  
 Insulation : Extruded PVC Material  
 Oversheath : Extruded Material (PVC or PE)

2-Cores CU/PVC/Sheathed 600/1000 V Cables as per IEC 60502-1							Continuous Current Rating		
Nominal Area	Number of Strands	Approx Conductor Diameter	Nominal Insulation Thickness	Nominal Outer Sheath Thickness	Approx. Overall Diameter*	Approx. Cable Weight	Ground	Duct [Gd]	Free Air
							Amps	Amps	Amps
mm	No.	mm	mm	mm	mm	kg/km			
2 x 1.5	7	1.6	0.8	1.8	13	210	19	16	13
2 x 2.5	7	2.0	0.8	1.8	14	250	25	21	17
2 x 4	7	2.6	1.0	1.8	16	340	33	28	23
2 x 6	7	3.1	1.0	1.8	17	410	41	35	29
2 x 10	7	4.0	1.0	1.8	19	540	55	47	39
2 x 16	7	5.0	1.0	1.8	21	720	71	60	52
2 x 25	7	6.3	1.2	1.8	24	1030	91	78	69
2 x 35	7	7.4	1.2	1.8	26	1300	109	94	84
2 x 50	19	8.8	1.4	1.8	30	1700	130	113	103
2 x 70	19	10.6	1.4	1.9	33	2260	159	139	129
2 x 95	19	12.4	1.6	2.0	39	3080	191	169	160
2 x 120	37	14.0	1.6	2.1	42	3740	217	193	185
2 x 150	37	15.5	1.8	2.2	46	4540	243	217	211
2 x 185	37	17.4	2.0	2.4	51	5690	273	247	241
2 x 240	61	20.3	2.2	2.6	58	7370	316	288	286
2 x 300	61	22.7	2.4	2.7	65	9160	355	326	327
2 x 400	61	25.4	2.6	3.0	71	11510	398	368	373
2 x 500	61	28.8	2.8	3.2	80	14580	445	415	425

\*Overall Diameter Tolerance Range: [-2% , +6%]



Conductor : Round Stranded Copper  
 Insulation : Extruded PVC Material  
 Oversheath : Extruded Material (PVC or PE)

3-Cores CU/PVC/Sheathed 600/1000 V Cables as per IEC 60502-1							Continuous Current Rating		
Nominal Area	Number of Strands	Approx Conductor Diameter	Nominal Insulation Thickness	Nominal Outer Sheath Thickness	Approx. Overall Diameter*	Approx. Cable Weight	Ground	Duct [Gd]	Free Air
							Amps	Amps	Amps
mm	No.	mm	mm	mm	mm	kg/km			
3 x 1.5	7	1.6	0.8	1.8	13	240	16	14	11
3 x 2.5	7	2.0	0.8	1.8	14	290	21	18	15
3 x 4	7	2.6	1.0	1.8	16	390	28	24	19
3 x 6	7	3.1	1.0	1.8	18	480	35	29	25
3 x 10	7	4.0	1.0	1.8	20	650	46	39	34
3 x 16	7	5.0	1.0	1.8	22	880	60	50	45
3 x 25	7	6.3	1.2	1.8	25	1280	77	65	59
3 x 35	7	7.4	1.2	1.8	28	1500	91	78	72
3 x 50	19	8.8	1.4	1.8	32	1950	108	94	87
3 x 70	19	10.6	1.4	2.0	36	2700	132	116	109
3 x 95	19	12.4	1.6	2.1	41	3630	158	139	134
3 x 120	37	14.0	1.6	2.2	45	4440	180	160	156
3 x 150	37	15.5	1.8	2.3	50	5440	201	180	178
3 x 185	37	17.4	2.0	2.5	55	6760	226	205	203
3 x 240	61	20.3	2.2	2.7	63	8800	261	238	240
3 x 300	61	22.7	2.4	2.9	69	10920	291	268	273
3 x 400	61	25.4	2.6	3.1	76	13770	327	304	311
3 x 500	61	28.8	2.8	3.4	86	17520	364	341	353

\*Overall Diameter Tolerance Range: [-2% , +6%]

## Multicore (Three and half & Four Cores) - Copper Conductor, PVC Insulated Cables

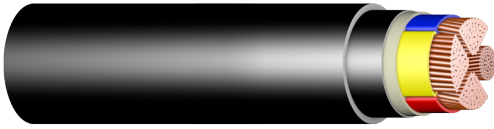

Conductor : Round / Sectoral Stranded Copper  
 Insulation : Extruded PVC Material  
 Oversheath : Extruded Material (PVC or PE)

3½ -Cores CU/PVC/Sheathed 600/1000 V Cables as per IEC 60502-1							Continuous Current Rating		
Nominal Area*	Number of Strands	Approx Conductor Diameter	Nominal Insulation Thickness	Nominal Outer Sheath Thickness	Approx. Overall Diameter*	Approx. Cable Weight	Ground	Duct [Gd]	Free Air
							Amps	Amps	Amps
mm	No.	mm	mm	mm	mm	kg/km			
3x16+10	7 / 7	5 / 4	1.0 / 1.0	1.8	23	1010	60	51	46
3x25+16	7 / 7	6.3 / 5	1.2 / 1.0	1.8	27	1460	78	67	61
3x35+16	7 / 7	6.6 / 5	1.2 / 1.0	1.8	27	1600	90	78	70
3x50+25	19 / 7	7.5 / 6.3	1.4 / 1.2	1.9	31	2150	107	93	86
3x70+35	19 / 7	9.1 / 7.4	1.4 / 1.2	2.0	35	2950	131	115	107
3x95+50	19 / 19	11 / 8.8	1.6 / 1.4	2.2	39	3980	156	138	131
3x120+70	37 / 19	12.2 / 10.6	1.6 / 1.4	2.3	43	4980	177	157	152
3x150+70	37 / 19	13.8 / 10.6	1.8 / 1.4	2.4	47	5950	198	177	173
3x185+95	37 / 19	15.1 / 12.4	2.0 / 1.6	2.6	52	7440	223	202	198
3x240+120	61 / 37	17.6 / 14	2.2 / 1.6	2.8	58	9600	257	234	232
3x300+150	61 / 37	19.8 / 15.5	2.4 / 1.8	3.0	64	11880	288	265	265
3x400+185	61 / 37	22.2 / 17.4	2.6 / 2.0	3.2	72	15060	325	300	304
3x500+240	61 / 61	26.3 / 20.3	2.8 / 2.2	3.5	79	19050	363	337	346

\*Sectoral Shape for conductor size > 25 mm<sup>2</sup>

\*\*Overall Diameter Tolerance Range: [-2% , +6%]

[Ph]: Phase [Ne]: Neutral



Conductor : Round / Sectoral Stranded Copper  
 Insulation : Extruded PVC Material  
 Oversheath : Extruded Material (PVC or PE)

4-Cores CU/PVC/Sheathed 600/1000 V Cables as per IEC 60502-1							Continuous Current Rating		
Nominal Area*	Number of Strands	Approx Conductor Diameter	Nominal Insulation Thickness	Nominal Outer Sheath Thickness	Approx. Overall Diameter*	Approx. Cable Weight	Ground	Duct [Gd]	Free Air
							Amps	Amps	Amps
mm	No.	mm	mm	mm	mm	kg/km			
4 x 1.5	7	1.6	0.8	1.8	14	270	17	14	11
4 x 2.5	7	2.0	0.8	1.8	15	340	22	18	15
4 x 4	7	2.6	1.0	1.8	18	470	28	24	20
4 x 6	7	3.1	1.0	1.8	19	580	35	30	25
4 x 10	7	4.0	1.0	1.8	21	800	47	40	35
4 x 16	7	5.0	1.0	1.8	24	1090	61	52	46
4 x 25	7	6.3	1.2	1.8	28	1600	78	67	62
4 x 35	7	6.6	1.2	1.8	28	1790	91	78	71
4 x 50	19	7.5	1.4	1.9	32	2390	107	94	86
4 x 70	19	9.1	1.4	2.1	36	3280	131	115	108
4 x 95	19	11.0	1.6	2.2	41	4430	157	139	133
4 x 120	37	12.2	1.6	2.4	45	5470	178	159	154
4 x 150	37	13.8	1.8	2.5	49	6720	199	179	175
4 x 185	37	15.1	2.0	2.7	55	8360	224	204	201
4 x 240	61	17.6	2.2	2.9	61	10790	259	237	236
4 x 300	61	19.8	2.4	3.1	67	13370	290	267	269
4 x 400	61	22.2	2.6	3.4	76	17030	327	304	309
4 x 500	61	26.3	2.8	3.6	83	21440	365	342	351

\*Sectoral Shape for conductor size > 25 mm<sup>2</sup>

\*\*Overall Diameter Tolerance Range: [-2% , +6%]



## Multicore (Five Cores) - Copper Conductor, PVC Insulated Cables

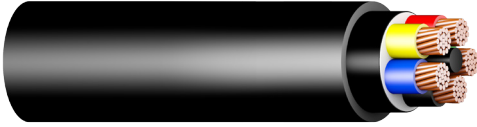

Conductor : Round Stranded Copper  
 Insulation : Extruded PVC Material  
 Oversheath : Extruded Material (PVC or PE)

5-Cores CU/PVC/Sheathed 600/1000 V Cables as per IEC 60502-1							Continuous Current Rating		
Nominal Area	Number of Strands	Approx Conductor Diameter	Nominal Insulation Thickness	Nominal Outer Sheath Thickness	Approx. Overall Diameter*	Approx. Cable Weight	Ground	Duct [Gd]	Free Air
							Amps	Amps	Amps
mm	No.	mm	mm	mm	mm	kg/km			
5 x 1.5	7	1.6	0.8	1.8	15	310	17	14	12
5 x 2.5	7	2.0	0.8	1.8	16	400	22	19	15
5 x 4	7	2.6	1.0	1.8	19	550	29	24	21
5 x 6	7	3.1	1.0	1.8	20	690	36	30	26
5 x 10	7	4.0	1.0	1.8	23	960	47	40	36
5 x 16	7	5.0	1.0	1.8	26	1330	61	53	48
5 x 25	7	6.3	1.2	1.8	30	1960	79	68	63
5 x 35	7	7.4	1.2	1.9	33	2390	95	82	78
5 x 50	19	8.8	1.4	2.1	39	3210	112	99	95
5 x 70	19	10.6	1.4	2.2	44	4360	138	122	120
5 x 95	19	12.4	1.6	2.4	51	5980	165	148	148
5 x 120	37	14.0	1.6	2.5	55	7320	187	169	171
5 x 150	37	15.5	1.8	2.7	61	8990	209	191	195
5 x 185	37	17.4	2.0	2.9	68	11180	236	217	224
5 x 240	61	20.3	2.2	3.1	77	14480	273	253	266
5 x 300	61	22.7	2.4	3.3	85	18080	305	284	302
5 x 400	61	25.4	2.6	3.7	95	22910	343	323	345
5 x 500	61	28.8	2.8	4.0	106	29110	382	362	391

\*Overall Diameter Tolerance Range: [-2% , +6%]

## Single Core - Aluminium Conductor, PVC Insulated Cables

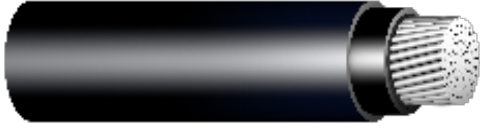

Conductor : Round Stranded Aluminium  
 Insulation : Extruded PVC Material  
 Oversheath : Extruded Material (PVC or PE)

1- Core AL/PVC/Sheathed 600/1000 V Cables as per IEC 60502-1

Nominal Area	Number of Strands	Approx Conductor Diameter	Nominal Insulation Thickness	Nominal Outer Sheath Thickness	Approx. Overall Diameter*	Approx. Cable Weight
mm	No.	mm	mm	mm	mm	kg/km
1 x 10	7	3.9	1.0	1.4	9	110
1 x 16	7	4.7	1.0	1.4	10	130
1 x 25	7	6.3	1.2	1.4	12	190
1 x 35	7	7.4	1.2	1.4	13	230
1 x 50	19	8.8	1.4	1.4	15	300
1 x 70	19	10.6	1.4	1.4	17	380
1 x 95	19	12.4	1.6	1.5	19	510
1 x 120	37	14.0	1.6	1.5	21	600
1 x 150	37	15.5	1.8	1.6	23	730
1 x 185	37	17.4	2.0	1.7	25	910
1 x 240	61	19.9	2.2	1.8	28	1150
1 x 300	61	22.2	2.4	1.9	31	1410
1 x 400	61	25.2	2.6	2.0	35	1770
1 x 500	61	28.6	2.8	2.1	39	2180
1 x 630	91	32.6	2.8	2.2	43	2740
1 x 800	91	36.7	2.8	2.3	47	3360

\*Overall Diameter Tolerance Range: [-2% , +6%]

Continuous Current Rating

Nominal Area	Trefoil [Gd]	Trefoil in One Duct [Gd]	Trefoil in Three Ducts [Gd]	Flat Touching [Gd]	Flat Spaced [Gd]	Flat Spaced in Three Ducts [Gd]	Trefoil [Air]	Flat Spaced [Air]	Flat Touching [Air]
mm	Amps	Amps	Amps	Amps	Amps	Amps	Amps	Amps	Amps
1 x 10	38	35	36	37	39	35	27	36	28
1 x 16	49	45	47	48	51	46	36	47	37
1 x 25	63	59	60	62	66	59	49	64	50
1 x 35	75	70	73	74	78	71	60	78	61
1 x 50	89	83	86	88	93	84	74	96	76
1 x 70	109	102	106	107	114	103	94	122	97
1 x 95	131	122	128	128	136	124	115	149	119
1 x 120	149	140	145	145	155	142	136	174	140
1 x 150	167	157	163	163	174	160	156	199	161
1 x 185	188	178	184	184	197	181	180	229	186
1 x 240	219	208	214	213	229	211	215	273	222
1 x 300	247	235	244	240	259	240	250	315	258
1 x 400	283	270	283	274	298	278	295	372	305
1 x 500	322	309	325	312	342	319	346	437	358
1 x 630	365	351	372	354	391	366	404	513	418
1 x 800	409	393	420	395	443	416	463	594	479

- When cables are arranged in spaced at formation they are spaced by one cable diameter.



## Multicore (Two & Three Cores) - Aluminium Conductor, PVC Insulated Cables

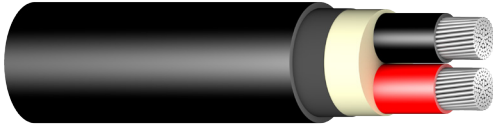

Conductor : Round Stranded Aluminium  
 Insulation : Extruded PVC Material  
 Oversheath : Extruded Material (PVC or PE)

2-Cores AL/PVC/Sheathed 600/1000 V Cables as per IEC 60502-1							Continuous Current Rating		
Nominal Area	Number of Strands	Approx Conductor Diameter	Nominal Insulation Thickness	Nominal Outer Sheath Thickness	Approx. Overall Diameter*	Approx. Cable Weight	Ground	Duct [Gd]	Free Air
							Amps	Amps	Amps
mm	No.	mm	mm	mm	mm	kg/km			
2 x 10	7	3.9	1.0	1.8	18	400	42	35	30
2 x 16	7	4.7	1.0	1.8	19	490	54	46	39
2 x 25	7	6.3	1.2	1.8	23	710	71	60	53
2 x 35	7	7.4	1.2	1.8	26	860	85	73	65
2 x 50	19	8.8	1.4	1.8	29	1100	100	87	79
2 x 70	19	10.6	1.4	1.9	33	1430	124	108	100
2 x 95	19	12.4	1.6	2.0	38	1910	148	131	123
2 x 120	37	14.0	1.6	2.1	41	2270	168	149	143
2 x 150	37	15.5	1.8	2.2	45	2730	189	168	163
2 x 185	37	17.4	2.0	2.4	51	3420	214	193	189
2 x 240	61	19.9	2.2	2.6	57	4330	248	226	223
2 x 300	61	22.2	2.4	2.7	63	5320	280	256	256
2 x 400	61	25.2	2.6	3.0	70	6650	320	296	299
2 x 500	61	28.6	2.8	3.2	79	8310	365	339	348

\*Overall Diameter Tolerance Range: [-2% , +6%]



Conductor : Round Stranded Aluminium  
 Insulation : Extruded PVC Material  
 Oversheath : Extruded Material (PVC or PE)

3-Cores AL/PVC/Sheathed 600/1000 V Cables as per IEC 60502-1							Continuous Current Rating		
Nominal Area	Number of Strands	Approx Conductor Diameter	Nominal Insulation Thickness	Nominal Outer Sheath Thickness	Approx. Overall Diameter*	Approx. Cable Weight	Ground	Duct [Gd]	Free Air
							Amps	Amps	Amps
mm	No.	mm	mm	mm	mm	kg/km			
3 x 10	7	3.9	1.0	1.8	19	450	35	30	26
3 x 16	7	4.7	1.0	1.8	21	560	46	39	34
3 x 25	7	6.3	1.2	1.8	25	810	60	51	46
3 x 35	7	7.4	1.2	1.8	28	870	71	61	56
3 x 50	19	8.8	1.4	1.8	32	1100	84	73	68
3 x 70	19	10.6	1.4	2.0	36	1470	103	90	85
3 x 95	19	12.4	1.6	2.1	41	1920	123	108	105
3 x 120	37	14.0	1.6	2.2	45	2280	140	125	122
3 x 150	37	15.5	1.8	2.3	50	2780	157	140	139
3 x 185	37	17.4	2.0	2.5	55	3420	177	161	160
3 x 240	61	19.9	2.2	2.7	62	4360	206	188	189
3 x 300	61	22.2	2.4	2.9	68	5310	232	213	216
3 x 400	61	25.2	2.6	3.1	76	6600	265	246	252
3 x 500	61	28.6	2.8	3.4	85	8250	301	281	292

\*Overall Diameter Tolerance Range: [-2% , +6%]

## Multicore (Three and half & Four Cores) - Aluminium Conductor, PVC Insulated Cables

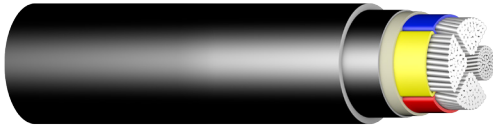

Conductor : Round / Sectoral Stranded Aluminium  
 Insulation : Extruded PVC Material  
 Oversheath : Extruded Material (PVC or PE)

3 1/2 -Cores AL/PVC/Sheathed 600/1000 V Cables as per IEC 60502-1							Continuous Current Rating		
Nominal Area*	Number of Strands	Approx Conductor Diameter	Nominal Insulation Thickness	Nominal Outer Sheath Thickness	Approx. Overall Diameter**	Approx. Cable Weight	Ground	Duct [Gd]	Free Air
							Amps	Amps	Amps
mm	No.	mm	mm	mm	mm	kg/km			
3x16+10	7 / 7	4.7 / 3.9	1.0 / 1.0	1.8	22	640	46	39	35
3x25+16	7 / 7	6.3 / 4.7	1.2 / 1.0	1.8	26	900	60	52	47
3x35+16	7 / 7	6.5 / 4.7	1.2 / 1.0	1.8	27	870	70	60	55
3x50+25	7 / 7	7.5 / 6.3	1.4 / 1.2	1.9	31	1150	83	72	66
3x70+35	14 / 7	9.1 / 7.4	1.4 / 1.2	2.0	35	1490	102	89	83
3x95+50	19 / 19	10.8 / 8.8	1.6 / 1.4	2.2	39	1960	121	107	102
3x120+70	19 / 19	12.2 / 10.6	1.6 / 1.4	2.3	43	2380	138	123	118
3x150+70	37 / 19	13.5 / 10.6	1.8 / 1.4	2.4	47	2820	155	138	135
3x185+95	37 / 19	15.2 / 12.4	2.0 / 1.6	2.6	52	3480	175	158	155
3x240+120	37 / 37	17.5 / 14	2.2 / 1.6	2.8	58	4430	203	185	183
3x300+150	37 / 37	19.6 / 15.5	2.4 / 1.8	3.0	64	5380	229	210	210
3x400+185	61 / 37	22.5 / 17.4	2.6 / 2.0	3.2	72	6790	262	242	245
3x500+240	61 / 61	25.6 / 19.9	2.8 / 2.2	3.5	79	8410	298	277	284

\*Sectoral Shape for conductor size > 25 mm<sup>2</sup>

\*\*Overall Diameter Tolerance Range: [-2% , +6%]

[Ph]: Phase [Ne]: Neutral



Conductor : Round / Sectoral Stranded Aluminium  
 Insulation : Extruded PVC Material  
 Oversheath : Extruded Material (PVC or PE)

4-Cores AL/PVC/Sheathed 600/1000 V Cables as per IEC 60502-1							Continuous Current Rating		
Nominal Area*	Number of Strands	Approx Conductor Diameter	Nominal Insulation Thickness	Nominal Outer Sheath Thickness	Approx. Overall Diameter**	Approx. Cable Weight	Ground	Duct [Gd]	Free Air
							Amps	Amps	Amps
mm	No.	mm	mm	mm	mm	kg/km			
4 x 10	7	3.9	1.0	1.8	20	540	36	30	26
4 x 16	7	4.7	1.0	1.8	22	670	46	39	35
4 x 25	7	6.3	1.2	1.8	27	990	61	52	48
4 x 35	7	6.5	1.2	1.8	28	940	70	61	55
4 x 50	7	7.5	1.4	1.9	32	1260	83	73	67
4 x 70	14	9.1	1.4	2.1	36	1610	102	90	84
4 x 95	19	10.8	1.6	2.2	41	2110	122	108	103
4 x 120	19	12.2	1.6	2.4	45	2550	139	124	120
4 x 150	37	13.5	1.8	2.5	49	3090	155	140	136
4 x 185	37	15.2	2.0	2.7	55	3830	176	160	157
4 x 240	37	17.5	2.2	2.9	61	4850	204	186	186
4 x 300	37	19.6	2.4	3.1	67	5890	230	212	213
4 x 400	61	22.5	2.6	3.4	76	7490	263	245	249
4 x 500	61	25.6	2.8	3.6	83	9210	300	280	288

\*Sectoral Shape for conductor size > 25 mm<sup>2</sup>

\*\*Overall Diameter Tolerance Range: [-2% , +6%]



## Multicore (Five Cores) - Aluminium Conductor, PVC Insulated Cables



Conductor : Round Stranded Aluminium  
 Insulation : Extruded PVC Material  
 Oversheath : Extruded Material (PVC or PE)

5-Cores AL/PVC/Sheathed 600/1000 V Cables as per IEC 60502-1							Continuous Current Rating		
Nominal Area	Number of Strands	Approx Conductor Diameter	Nominal Insulation Thickness	Nominal Outer Sheath Thickness	Approx. Overall Diameter*	Approx. Cable Weight	Ground	Duct [Gd]	Free Air
							Amps	Amps	Amps
mm	No.	mm	mm	mm	mm	kg/km			
5 x 10	7	3.9	1.0	1.8	22	640	36	31	27
5 x 16	7	4.7	1.0	1.8	24	810	47	40	36
5 x 25	7	6.3	1.2	1.8	30	1200	61	53	49
5 x 35	7	7.4	1.2	1.9	33	1340	73	64	60
5 x 50	19	8.8	1.4	2.1	39	1790	87	77	74
5 x 70	19	10.6	1.4	2.2	44	2330	107	95	93
5 x 95	19	12.4	1.6	2.4	51	3130	128	115	115
5 x 120	37	14	1.6	2.5	55	3720	146	132	133
5 x 150	37	15.5	1.8	2.7	61	4560	163	149	152
5 x 185	37	17.4	2.0	2.9	68	5610	185	170	176
5 x 240	61	19.9	2.2	3.1	76	7080	215	199	209
5 x 300	61	22.2	2.4	3.3	84	8720	243	226	239
5 x 400	61	25.2	2.6	3.7	94	10940	277	261	279
5 x 500	61	28.6	2.8	4.0	105	13650	316	300	323

\*Overall Diameter Tolerance Range: [-2% , +6%]

## Single Core - Copper Conductor, XLPE Insulated CU Shielded Cables



Conductor : Round Stranded Copper  
 Insulation : Extruded XLPE Material  
 Shield : Copper Tape Screen  
 Oversheath : Extruded Material (PVC, LSF or PE)

1-Core CU/XLPE/CUT/Sheathed 600/1000 V Cables as per IEC 60502-1

Nominal Area	Number of Strands	Approx Conductor Diameter	Nominal Insulation Thickness	Nominal Outer Sheath Thickness	Approx. Overall Diameter*	Approx. Cable Weight
mm	No.	mm	mm	mm	mm	kg/km
1 x 1.5	7	1.6	0.7	1.4	9	100
1 x 2.5	7	2.0	0.7	1.4	9	120
1 x 4	7	2.6	0.7	1.4	10	140
1 x 6	7	3.1	0.7	1.4	10	170
1 x 10	7	4.0	0.7	1.4	11	220
1 x 16	7	5.0	0.7	1.4	12	290
1 x 25	7	6.3	0.9	1.4	14	400
1 x 35	7	7.4	0.9	1.4	15	510
1 x 50	19	8.8	1.0	1.4	16	640
1 x 70	19	10.6	1.1	1.5	19	870
1 x 95	19	12.4	1.1	1.5	20	1140
1 x 120	37	14.0	1.2	1.6	22	1410
1 x 150	37	15.5	1.4	1.6	24	1690
1 x 185	37	17.4	1.6	1.7	27	2090
1 x 240	61	20.3	1.7	1.8	30	2680
1 x 300	61	22.7	1.8	1.9	33	3310
1 x 400	61	25.4	2.0	2.0	37	4220
1 x 500	61	28.8	2.2	2.1	41	5330
1 x 630	61	30.4	2.4	2.2	43	6610
1 x 800	61	33.7	2.6	2.3	47	8380

\*Overall Diameter Tolerance Range: [-2% , +6%]

Continuous Current Rating

Nominal Area	Trefoil [Gd]	Trefoil in One Duct [Gd]	Trefoil in Three Ducts [Gd]	Flat Touching [Gd]	Flat Spaced [Gd]	Flat Spaced in Three Ducts [Gd]	Trefoil [Air]	Flat Spaced [Air]	Flat Touching [Air]
mm	Amps	Amps	Amps	Amps	Amps	Amps	Amps	Amps	Amps
1 x 1.5	23	21	22	24	24	21	21	26	21
1 x 2.5	30	27	28	30	31	28	27	34	28
1 x 4	38	35	37	39	40	36	36	46	37
1 x 6	47	44	46	48	49	44	44	57	46
1 x 10	62	58	60	64	65	58	60	78	62
1 x 16	80	74	77	82	83	75	80	102	82
1 x 25	103	96	100	105	107	97	107	137	110
1 x 35	123	115	118	126	128	115	131	167	134
1 x 50	145	135	141	148	151	137	157	201	162
1 x 70	178	167	174	182	185	169	202	256	208
1 x 95	211	199	206	216	220	201	245	311	253
1 x 120	240	226	233	245	250	228	286	362	295
1 x 150	269	254	263	275	281	257	328	413	338
1 x 185	304	289	300	311	318	293	383	480	395
1 x 240	351	334	349	359	369	341	456	572	470
1 x 300	395	377	396	403	416	386	526	659	542
1 x 400	445	426	450	455	472	439	610	763	628
1 x 500	499	479	512	510	534	499	702	884	724
1 x 630	552	530	577	563	597	560	784	997	808
1 x 800	605	583	642	617	663	623	878	1124	904

- When cables are arranged in spaced formation they are spaced by one cable diameter.



## Multicore (2 & 3 Cores) - Copper Conductor, XLPE Insulated CU Shielded Cables



Conductor : Round Stranded Copper  
 Insulation : Extruded XLPE Material  
 Shield : Copper Tape Screen  
 Oversheath : Extruded Material (PVC, LSF or PE)

2-Cores CU/XLPE/CUT/Sheathed 600/1000 V Cables as per IEC 60502-1							Continuous Current Rating		
Nominal Area	Number of Strands	Approx Conductor Diameter	Nominal Insulation Thickness	Nominal Outer Sheath Thickness	Approx. Overall Diameter*	Approx. Cable Weight	Ground	Duct [Gd]	Free Air
							Amps	Amps	Amps
mm	No.	mm	mm	mm	mm	kg/km			
2 x 1.5	7	1.6	0.7	1.8	13	220	25	21	21
2 x 2.5	7	2.0	0.7	1.8	14	260	32	27	28
2 x 4	7	2.6	0.7	1.8	15	320	42	35	36
2 x 6	7	3.1	0.7	1.8	16	390	52	44	46
2 x 10	7	4.0	0.7	1.8	18	520	70	58	63
2 x 16	7	5.0	0.7	1.8	20	690	90	76	84
2 x 25	7	6.3	0.9	1.8	23	990	116	99	111
2 x 35	7	7.4	0.9	1.8	25	1250	139	118	136
2 x 50	19	8.8	1.0	1.8	28	1610	164	141	165
2 x 70	19	10.6	1.1	1.9	33	2190	202	176	210
2 x 95	19	12.4	1.1	2.0	37	2920	241	211	257
2 x 120	37	14.0	1.2	2.1	41	3610	274	241	298
2 x 150	37	15.5	1.4	2.2	45	4380	308	274	340
2 x 185	37	17.4	1.6	2.3	50	5460	346	310	389
2 x 240	61	20.3	1.7	2.5	56	7050	401	362	461
2 x 300	61	22.7	1.8	2.7	62	8760	449	410	525
2 x 400	61	25.4	2.0	2.9	69	11010	506	465	603
2 x 500	61	28.8	2.2	3.1	77	13910	566	525	687

\*Overall Diameter Tolerance Range: [-2% , +6%]



Conductor : Round Stranded Copper  
 Insulation : Extruded XLPE Material  
 Shield : Copper Tape Screen  
 Oversheath : Extruded Material (PVC, LSF or PE)

3-Cores CU/XLPE/CUT/Sheathed 600/1000 V Cables as per IEC 60502-1							Continuous Current Rating		
Nominal Area	Number of Strands	Approx Conductor Diameter	Nominal Insulation Thickness	Nominal Outer Sheath Thickness	Approx. Overall Diameter*	Approx. Cable Weight	Ground	Duct [Gd]	Free Air
							Amps	Amps	Amps
mm	No.	mm	mm	mm	mm	kg/km			
3 x 1.5	7	1.6	0.7	1.8	13	240	21	18	18
3 x 2.5	7	2.0	0.7	1.8	14	300	28	23	24
3 x 4	7	2.6	0.7	1.8	15	370	36	29	31
3 x 6	7	3.1	0.7	1.8	17	450	44	37	40
3 x 10	7	4.0	0.7	1.8	19	620	59	50	55
3 x 16	7	5.0	0.7	1.8	21	840	76	64	72
3 x 25	7	6.3	0.9	1.8	24	1220	98	83	96
3 x 35	7	7.4	0.9	1.8	27	1450	115	99	115
3 x 50	19	8.8	1.0	1.8	30	1860	137	118	140
3 x 70	19	10.6	1.1	1.9	35	2590	167	146	176
3 x 95	19	12.4	1.1	2.0	39	3450	200	176	216
3 x 120	37	14.0	1.2	2.2	44	4280	227	201	251
3 x 150	37	15.5	1.4	2.3	48	5250	254	227	285
3 x 185	37	17.4	1.6	2.4	53	6490	286	257	327
3 x 240	61	20.3	1.7	2.6	61	8440	330	301	387
3 x 300	61	22.7	1.8	2.8	67	10440	369	339	440
3 x 400	61	25.4	2.0	3.1	74	13240	414	382	501
3 x 500	61	28.8	2.2	3.3	83	16830	461	430	568

\*Overall Diameter Tolerance Range: [-2% , +6%]

## Multicore (3½ & 4 Cores) - Copper Conductor, XLPE Insulated CU Shielded Cables

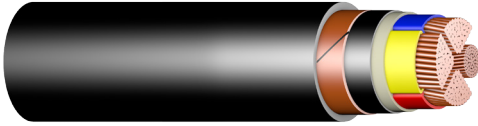

Conductor : Round / Sectoral Stranded Copper  
 Insulation : Extruded XLPE Material  
 Shield : Copper Tape Screen  
 Oversheath : Extruded Material (PVC, LSF or PE)

3½ Cores CU/XLPE/CUT/Sheathed 600/1000 V Cables as per IEC 60502-1							Continuous Current Rating		
Nominal Area*	Number of Strands	Approx Conductor Diameter	Nominal Insulation Thickness	Nominal Outer Sheath Thickness	Approx. Overall Diameter**	Approx. Cable Weight	Ground	Duct [Gd]	Free Air
							Amps	Amps	Amps
mm	No.	mm	mm	mm	mm	kg/km			
3x16+10	7 / 7	5 / 4	0.7 / 0.7	1.8	22	960	77	64	74
3x25+16	7 / 7	6.3 / 5	0.9 / 0.7	1.8	25	1380	98	83	98
3x35+16	7 / 7	6.6 / 5	0.9 / 0.7	1.8	26	1540	114	98	113
3x50+25	19 / 7	7.5 / 6.3	1.0 / 0.9	1.8	29	2020	135	117	137
3x70+35	19 / 7	9.1 / 7.4	1.1 / 0.9	2.0	33	2840	165	143	171
3x95+50	19 / 19	11 / 8.8	1.1 / 1.0	2.1	37	3760	198	173	211
3x120+70	37 / 19	12.2 / 10.6	1.2 / 1.1	2.2	41	4720	224	197	244
3x150+70	37 / 19	13.8 / 10.6	1.4 / 1.1	2.3	45	5690	251	224	278
3x185+95	37 / 19	15.1 / 12.4	1.6 / 1.1	2.5	50	7120	283	253	318
3x240+120	61 / 37	17.6 / 14	1.7 / 1.2	2.7	56	9190	326	295	374
3x300+150	61 / 37	19.8 / 15.5	1.8 / 1.4	2.9	61	11340	365	333	426
3x400+185	61 / 37	22.2 / 17.4	2.0 / 1.6	3.2	69	14370	412	378	490
3x500+240	61 / 61	26.3 / 20.3	2.2 / 1.7	3.4	76	18270	461	428	557

\*Sectoral Shape for conductor size > 25 mm<sup>2</sup>

\*\*Overall Diameter Tolerance Range: [-2% , +6%]

[Ph]: Phase [Ne]: Neutral

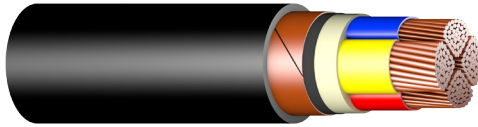

Conductor : Round / Sectoral Stranded Copper  
 Insulation : Extruded XLPE Material  
 Shield : Copper Tape Screen  
 Oversheath : Extruded Material (PVC, LSF or PE)

4-Cores CU/XLPE/CUT/Sheathed 600/1000 V Cables as per IEC 60502-1							Continuous Current Rating		
Nominal Area*	Number of Strands	Approx Conductor Diameter	Nominal Insulation Thickness	Nominal Outer Sheath Thickness	Approx. Overall Diameter**	Approx. Cable Weight	Ground	Duct [Gd]	Free Air
							Amps	Amps	Amps
mm	No.	mm	mm	mm	mm	kg/km			
4 x 1.5	7	1.6	0.7	1.8	14	270	21	18	18
4 x 2.5	7	2	0.7	1.8	15	340	28	23	24
4 x 4	7	2.6	0.7	1.8	16	430	36	30	32
4 x 6	7	3.1	0.7	1.8	18	540	45	37	41
4 x 10	7	4	0.7	1.8	20	740	59	50	56
4 x 16	7	5	0.7	1.8	22	1030	77	64	74
4 x 25	7	6.3	0.9	1.8	26	1510	99	84	99
4 x 35	7	6.6	0.9	1.8	27	1720	115	98	115
4 x 50	19	7.5	1.0	1.9	30	2240	136	117	138
4 x 70	19	9.1	1.1	2.0	35	3150	166	145	174
4 x 95	19	11	1.1	2.2	39	4210	199	175	214
4 x 120	37	12.2	1.2	2.3	43	5240	225	199	246
4 x 150	37	13.8	1.4	2.5	48	6460	252	226	282
4 x 185	37	15.1	1.6	2.6	52	7960	284	256	321
4 x 240	61	17.6	1.7	2.8	59	10330	328	298	379
4 x 300	61	19.8	1.8	3.0	64	12780	367	336	431
4 x 400	61	22.2	2.0	3.3	73	16310	414	383	495
4 x 500	61	26.3	2.2	3.6	81	20630	464	432	565

\*Sectoral Shape for conductor size > 25 mm<sup>2</sup>

\*\*Overall Diameter Tolerance Range: [-2% , +6%]



## Multicore (5 Cores) - Copper Conductor, XLPE Insulated CU Shielded Cables

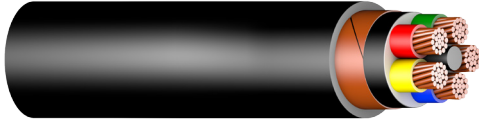

Conductor : Round Stranded Copper  
 Insulation : Extruded XLPE Material  
 Shield : Copper Tape Screen  
 Oversheath : Extruded Material (PVC, LSF or PE)

5-Cores CU/XLPE/CUT/Sheathed 600/1000 V Cables as per IEC 60502-1							Continuous Current Rating		
Nominal Area	Number of Strands	Approx Conductor Diameter	Nominal Insulation Thickness	Nominal Outer Sheath Thickness	Approx. Overall Diameter*	Approx. Cable Weight	Ground	Duct [Gd]	Free Air
							Amps	Amps	Amps
5 x 1.5	7	1.6	0.7	1.8	15	310			
5 x 2.5	7	2	0.7	1.8	16	390	21	18	19
5 x 4	7	2.6	0.7	1.8	18	500	28	23	25
5 x 6	7	3.1	0.7	1.8	19	630	36	30	33
5 x 10	7	4	0.7	1.8	22	890	45	38	42
5 x 16	7	5	0.7	1.8	24	1250	60	50	58
5 x 25	7	6.3	0.9	1.8	29	1840	77	65	76
5 x 35	7	7.4	0.9	1.9	32	2270	100	86	102
5 x 50	19	8.8	1.0	2.0	37	3010	120	104	125
5 x 70	19	10.6	1.1	2.1	42	4160	142	124	153
5 x 95	19	12.4	1.1	2.3	48	5630	173	153	193
5 x 120	37	14	1.2	2.4	53	6990	207	185	237
5 x 150	37	15.5	1.4	2.6	59	8530	236	211	275
5 x 185	37	17.4	1.6	2.8	66	10690	264	239	315
5 x 240	61	20.3	1.7	3.0	74	13810	298	272	361
5 x 300	61	22.7	1.8	3.3	82	17250	344	317	427
5 x 400	61	25.4	2.0	3.6	91	21880	385	357	486
5 x 500	61	28.8	2.2	3.9	102	27770	432	404	555
							483	457	632

\*Overall Diameter Tolerance Range: [-2% , +6%]

## Single Core - Aluminium Conductor, XLPE Insulated CU Shielded Cables



Conductor : Round Stranded Aluminium  
 Insulation : Extruded XLPE Material  
 Shield : Copper Tape Screen  
 Oversheath : Extruded Material (PVC, LSF or PE)

1- Core AL/XLPE/CUT/Sheathed 600/1000 V Cables as per IEC 60502-1						
Nominal Area	Number of Strands	Approx Conductor Diameter	Nominal Insulation Thickness	Nominal Outer Sheath Thickness	Approx. Overall Diameter*	Approx. Cable Weight
mm	No.	mm	mm	mm	mm	kg/km
1 x 10	7	3.9	0.7	1.4	11	160
1 x 16	7	4.7	0.7	1.4	12	190
1 x 25	7	6.3	0.9	1.4	14	250
1 x 35	7	7.4	0.9	1.4	15	300
1 x 50	19	8.8	1.0	1.4	16	360
1 x 70	19	10.6	1.1	1.5	19	470
1 x 95	19	12.4	1.1	1.5	20	570
1 x 120	37	14	1.2	1.6	22	690
1 x 150	37	15.5	1.4	1.6	24	810
1 x 185	37	17.4	1.6	1.7	27	980
1 x 240	61	19.9	1.7	1.8	30	1220
1 x 300	61	22.2	1.8	1.9	32	1460
1 x 400	61	25.2	2.0	2.0	36	1840
1 x 500	61	28.6	2.2	2.1	40	2250
1 x 630	91	32.6	2.4	2.2	45	2840
1 x 800	91	36.7	2.6	2.3	50	3550

\*Overall Diameter Tolerance Range: [-2% , +6%]

Continuous Current Rating									
Nominal Area	Trefoil [Gd]	Trefoil in One Duct [Gd]	Trefoil in ThreeDucts [Gd]	Flat Touching [Gd]	Flat Spaced [Gd]	Flat Spaced in Three Ducts [Gd]	Trefoil [Air]	Flat Spaced [Air]	Flat Touching [Air]
mm	Amps	Amps	Amps	Amps	Amps	Amps	Amps	Amps	Amps
1 x 10	48	44	46	49	50	45	46	60	48
1 x 16	62	57	59	63	64	58	61	79	63
1 x 25	80	75	77	82	83	75	83	106	86
1 x 35	95	89	92	97	99	89	101	129	104
1 x 50	112	105	109	115	117	106	122	156	125
1 x 70	138	130	135	141	144	131	157	199	162
1 x 95	164	154	160	168	171	156	190	242	196
1 x 120	187	176	181	191	195	177	223	281	229
1 x 150	209	198	204	214	218	200	255	321	263
1 x 185	238	226	233	243	248	228	299	374	309
1 x 240	276	263	272	282	288	266	358	446	369
1 x 300	310	296	309	317	324	301	410	511	423
1 x 400	355	340	355	363	372	346	483	598	498
1 x 500	405	389	407	414	425	397	567	701	584
1 x 630	462	444	470	471	487	458	665	824	686
1 x 800	518	500	532	529	551	519	766	951	790

- When cables are arranged in spaced at formation they are spaced by one cable diameter.



## Multicore (2 & 3 Cores) - Aluminium Conductor, XLPE Insulated CU Shielded Cables

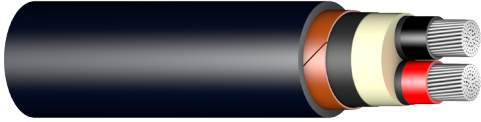

Conductor : Round Stranded Aluminium  
 Insulation : Extruded XLPE Material  
 Shield : Copper Tape Screen  
 Oversheath : Extruded Material (PVC, LSF or PE)

2-Cores AL/XLPE/CUT/Sheathed 600/1000 V Cables as per IEC 60502-1							Continuous Current Rating		
Nominal Area	Number of Strands	Approx Conductor Diameter	Nominal Insulation Thickness	Nominal Outer Sheath Thickness	Approx. Overall Diameter*	Approx. Cable Weight	Ground	Duct [Gd]	Free Air
							Amps	Amps	Amps
mm <sup>2</sup>	No.	mm	mm	mm	mm	kg/km			
2 x 10	7	3.9	0.7	1.8	17	380	53	45	48
2 x 16	7	4.7	0.7	1.8	19	460	69	58	63
2 x 25	7	6.3	0.9	1.8	23	670	90	77	86
2 x 35	7	7.4	0.9	1.8	25	810	107	91	105
2 x 50	19	8.8	1.0	1.8	28	1020	127	109	128
2 x 70	19	10.6	1.1	1.9	32	1360	156	136	162
2 x 95	19	12.4	1.1	2.0	36	1760	187	163	198
2 x 120	37	14	1.2	2.1	40	2140	213	188	231
2 x 150	37	15.5	1.4	2.2	44	2570	239	211	263
2 x 185	37	17.4	1.6	2.3	49	3200	270	242	303
2 x 240	61	19.9	1.7	2.5	55	4020	314	284	360
2 x 300	61	22.2	1.8	2.7	61	4930	354	323	412
2 x 400	61	25.2	2.0	2.9	68	6160	405	372	481
2 x 500	61	28.6	2.2	3.1	76	7650	463	430	561

\*Overall Diameter Tolerance Range: [-2% , +6%]

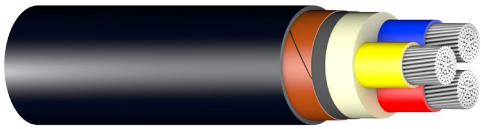

Conductor : Round Stranded Aluminium  
 Insulation : Extruded XLPE Material  
 Shield : Copper Tape Screen  
 Oversheath : Extruded Material (PVC, LSF or PE)

3-Cores AL/XLPE/CUT/Sheathed 600/1000 V Cables as per IEC 60502-1							Continuous Current Rating		
Nominal Area	Number of Strands	Approx Conductor Diameter	Nominal Insulation Thickness	Nominal Outer Sheath Thickness	Approx. Overall Diameter*	Approx. Cable Weight	Ground	Duct [Gd]	Free Air
							Amps	Amps	Amps
mm <sup>2</sup>	No.	mm	mm	mm	mm	kg/km			
3 x 10	7	3.9	0.7	1.8	18	420	45	38	41
3 x 16	7	4.7	0.7	1.8	20	520	58	49	55
3 x 25	7	6.3	0.9	1.8	24	750	76	64	75
3 x 35	7	7.4	0.9	1.8	27	810	90	77	89
3 x 50	19	8.8	1.0	1.8	30	1010	106	91	109
3 x 70	19	10.6	1.1	1.9	35	1370	130	113	137
3 x 95	19	12.4	1.1	2.0	39	1740	155	136	168
3 x 120	37	14	1.2	2.2	44	2120	177	156	196
3 x 150	37	15.5	1.4	2.3	48	2590	198	177	222
3 x 185	37	17.4	1.6	2.4	53	3150	224	201	256
3 x 240	61	19.9	1.7	2.6	60	4000	260	235	303
3 x 300	61	22.2	1.8	2.8	66	4840	293	268	348
3 x 400	61	25.2	2.0	3.1	74	6070	335	310	405
3 x 500	61	28.6	2.2	3.3	83	7570	381	355	469

\*Overall Diameter Tolerance Range: [-2% , +6%]

## Multicore (3½ & 4 Cores) - Aluminium Conductor, XLPE Insulated CU Shielded Cables

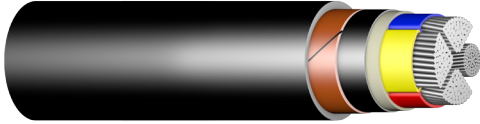

Conductor : Round / Sectoral Stranded Aluminium  
 Insulation : Extruded XLPE Material  
 Shield : Copper Tape Screen  
 Oversheath : Extruded Material (PVC, LSF or PE)

3½ -Cores AL/XLPE/CUT/Sheathed 600/1000 V Cables as per IEC 60502-1							Continuous Current Rating		
Nominal Area*	Number of Strands	Approx Conductor Diameter	Nominal Insulation Thickness	Nominal Outer Sheath Thickness	Approx. Overall Diameter**	Approx. Cable Weight	Ground	Duct [Gd]	Free Air
							Amps	Amps	Amps
mm	No.	mm	mm	mm	mm	kg/km			
3x16+10	7 / 7	4.7 / 3.9	0.7 / 0.7	1.8	21	580	59	49	56
3x25+16	7 / 7	6.3 / 4.7	0.9 / 0.7	1.8	25	820	76	64	76
3x35+16	7 / 7	6.5 / 4.7	0.9 / 0.7	1.8	26	810	89	76	88
3x50+25	7 / 7	7.5 / 6.3	1.0 / 0.9	1.8	29	1020	105	91	106
3x70+35	14 / 7	9.1 / 7.4	1.1 / 0.9	2.0	33	1380	128	111	133
3x95+50	19 / 19	10.8 / 8.8	1.1 / 1.0	2.1	37	1740	153	134	163
3x120+70	19 / 19	12.2 / 10.6	1.2 / 1.1	2.2	41	2120	175	154	190
3x150+70	37 / 19	13.5 / 10.6	1.4 / 1.1	2.3	45	2560	195	174	216
3x185+95	37 / 19	15.2 / 12.4	1.6 / 1.1	2.5	50	3160	221	198	249
3x240+120	37 / 37	17.5 / 14	1.7 / 1.2	2.7	56	4010	256	232	294
3x300+150	37 / 37	19.6 / 15.5	1.8 / 1.4	2.9	61	4840	289	264	337
3x400+185	61 / 37	22.5 / 17.4	2.0 / 1.6	3.2	69	6100	331	304	394
3x500+240	61 / 61	25.6 / 19.9	2.2 / 1.7	3.4	76	7630	377	350	455

\*Sectoral Shape for conductor size > 25 mm<sup>2</sup>

\*\*Overall Diameter Tolerance Range: [-2% , +6%]

[Ph]: Phase [Ne]: Neutral

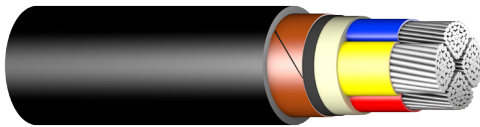

Conductor : Round / Sectoral Stranded Aluminium  
 Insulation : Extruded XLPE Material  
 Shield : Copper Tape Screen  
 Oversheath : Extruded Material (PVC, LSF or PE)

4-Cores AL/XLPE/CUT/Sheathed 600/1000 V Cables as per IEC 60502-1							Continuous Current Rating		
Nominal Area*	Number of Strands	Approx Conductor Diameter	Nominal Insulation Thickness	Nominal Outer Sheath Thickness	Approx. Overall Diameter**	Approx. Cable Weight	Ground	Duct [Gd]	Free Air
							Amps	Amps	Amps
mm	No.	mm	mm	mm	mm	kg/km			
4 x 10	7	3.9	0.7	1.8	19	490	45	38	42
4 x 16	7	4.7	0.7	1.8	21	610	59	49	56
4 x 25	7	6.3	0.9	1.8	26	900	77	65	77
4 x 35	7	6.5	0.9	1.8	27	870	89	76	89
4 x 50	7	7.5	1.0	1.9	30	1100	105	91	107
4 x 70	14	9.1	1.1	2.0	35	1470	129	113	135
4 x 95	19	10.8	1.1	2.2	39	1900	154	136	166
4 x 120	19	12.2	1.2	2.3	43	2320	175	155	192
4 x 150	37	13.5	1.4	2.5	48	2830	196	176	219
4 x 185	37	15.2	1.6	2.6	52	3440	222	200	252
4 x 240	37	17.5	1.7	2.8	59	4390	258	234	298
4 x 300	37	19.6	1.8	3.0	64	5300	291	266	341
4 x 400	61	22.5	2.0	3.3	73	6770	333	308	398
4 x 500	61	25.6	2.2	3.6	81	8410	379	353	462

\*Sectoral Shape for conductor size > 25 mm<sup>2</sup>



\*\*Overall Diameter Tolerance Range: [-2% , +6%]



## Multicore (Five Cores) - Aluminium Conductor, XLPE Insulated CU Shielded Cables



Conductor : Round Stranded Aluminium  
 Insulation : Extruded XLPE Material  
 Shield : Copper Tape Screen  
 Oversheath : Extruded Material (PVC, LSF or PE)

5-Cores AL/XLPE/CUT/Sheathed 600/1000 V Cables as per IEC 60502-1							Continuous Current Rating		
Nominal Area	Number of Strands	Approx Conductor Diameter	Nominal Insulation Thickness	Nominal Outer Sheath Thickness	Approx. Overall Diameter*	Approx. Cable Weight	Ground	Duct [Gd]	Free Air
							Amps	Amps	Amps
mm	No.	mm	mm	mm	mm	kg/km			
5 x 10	7	3.9	0.7	1.8	21	570	46	39	44
5 x 16	7	4.7	0.7	1.8	23	730	59	50	58
5 x 25	7	6.3	0.9	1.8	28	1080	77	66	79
5 x 35	7	7.4	0.9	1.9	32	1220	93	80	97
5 x 50	19	8.8	1.0	2.0	37	1590	110	96	119
5 x 70	19	10.6	1.1	2.1	42	2130	135	119	150
5 x 95	19	12.4	1.1	2.3	48	2790	161	144	184
5 x 120	37	14	1.2	2.4	53	3390	184	165	214
5 x 150	37	15.5	1.4	2.6	59	4100	206	186	245
5 x 185	37	17.4	1.6	2.8	66	5120	234	213	283
5 x 240	61	19.9	1.7	3.0	73	6420	271	250	335
5 x 300	61	22.2	1.8	3.3	81	7910	306	284	384
5 x 400	61	25.2	2.0	3.6	91	9920	350	328	449
5 x 500	61	28.6	2.2	3.9	102	12330	399	378	522

\*Overall Diameter Tolerance Range: [-2% , +6%]

## Single Core - Copper Conductor, PVC Insulated CU Shielded Cables

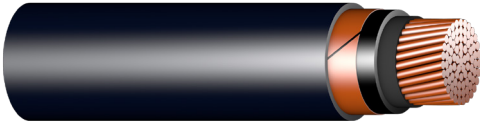

Conductor : Round Stranded Copper  
 Insulation : Extruded PVC Material  
 Shield : Copper Tape Screen  
 Oversheath : Extruded Material (PVC or PE)

**1-Core CU/PVC/CUT/Sheathed 600/1000 V Cables as per IEC 60502-1**

Nominal Area	Number of Strands	Approx Conductor Diameter	Nominal Insulation Thickness	Nominal Outer Sheath Thickness	Approx. Overall Diameter*	Approx. Cable Weight
mm	No.	mm	mm	mm	mm	kg/km
1 x 1.5	7	1.6	0.8	1.4	9	110
1 x 2.5	7	2.0	0.8	1.4	9	130
1 x 4	7	2.6	1.0	1.4	10	160
1 x 6	7	3.1	1.0	1.4	11	190
1 x 10	7	4.0	1.0	1.4	12	240
1 x 16	7	5.0	1.0	1.4	13	310
1 x 25	7	6.3	1.2	1.4	14	430
1 x 35	7	7.4	1.2	1.4	15	550
1 x 50	19	8.8	1.4	1.4	17	700
1 x 70	19	10.6	1.4	1.5	19	930
1 x 95	19	12.4	1.6	1.5	21	1220
1 x 120	37	14.0	1.6	1.6	23	1490
1 x 150	37	15.5	1.8	1.7	25	1800
1 x 185	37	17.4	2.0	1.7	28	2210
1 x 240	61	20.3	2.2	1.8	31	2840
1 x 300	61	22.7	2.4	1.9	34	3510
1 x 400	61	25.4	2.6	2.0	38	4450
1 x 500	61	28.8	2.8	2.1	42	5600
1 x 630	61	30.4	2.8	2.2	44	6830
1 x 800	61	33.7	2.8	2.4	48	8610

\*Overall Diameter Tolerance Range: [-2% , +6%]

**Continuous Current Rating**

Nominal Area	Trefoil [Gd]	Trefoil in One Duct [Gd]	Trefoil in Three Ducts [Gd]	Flat Touching [Gd]	Flat Spaced [Gd]	Flat Spaced in Three Ducts [Gd]	Trefoil [Air]	Flat Spaced [Air]	Flat Touching [Air]
mm	Amps	Amps	Amps	Amps	Amps	Amps	Amps	Amps	Amps
1 x 1.5	18	17	17	19	19	17	13	16	13
1 x 2.5	23	22	22	24	24	22	16	21	17
1 x 4	30	28	29	31	31	28	22	28	23
1 x 6	38	35	36	39	39	35	28	36	29
1 x 10	50	46	48	51	52	47	38	49	39
1 x 16	64	60	62	65	67	60	50	64	51
1 x 25	82	76	79	83	85	77	65	84	67
1 x 35	97	91	94	100	101	92	80	102	82
1 x 50	115	108	112	118	120	109	98	124	101
1 x 70	141	133	138	144	147	134	123	157	127
1 x 95	169	159	164	172	175	160	152	192	156
1 x 120	191	181	188	195	199	183	177	223	182
1 x 150	214	203	209	219	223	205	202	254	208
1 x 185	242	230	238	247	253	233	236	295	243
1 x 240	279	266	277	285	293	271	280	350	288
1 x 300	313	300	314	320	330	306	322	402	331
1 x 400	353	339	361	360	373	350	372	464	383
1 x 500	395	380	409	403	422	396	427	537	440
1 x 630	436	420	455	445	471	442	478	606	492
1 x 800	477	460	511	487	523	493	534	684	550

- When cables are arranged in spaced formation they are spaced by one cable diameter.



## Multicore (2 & 3 Cores) - Copper Conductor, PVC Insulated CU Shielded Cables

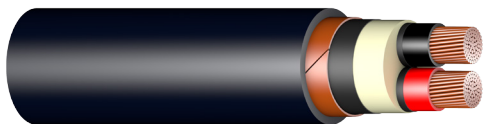

Conductor : Round Stranded Copper  
 Insulation : Extruded PVC Material  
 Shield : Copper Tape Screen  
 Oversheath : Extruded Material (PVC or PE)

2-Cores CU/PVC/CUT/Sheathed 600/1000 V Cables as per IEC 60502-1							Continuous Current Rating		
Nominal Area	Number of Strands	Approx Conductor Diameter	Nominal Insulation Thickness	Nominal Outer Sheath Thickness	Approx. Overall Diameter*	Approx. Cable Weight	Ground	Duct [Gd]	Free Air
							Amps	Amps	Amps
mm	No.	mm	mm	mm	mm	kg/km			
2 x 1.5	7	1.6	0.8	1.8	13	240	19	16	13
2 x 2.5	7	2.0	0.8	1.8	14	290	25	21	17
2 x 4	7	2.6	1.0	1.8	16	380	32	28	22
2 x 6	7	3.1	1.0	1.8	17	450	40	34	28
2 x 10	7	4.0	1.0	1.8	19	580	54	46	39
2 x 16	7	5.0	1.0	1.8	21	770	70	60	51
2 x 25	7	6.3	1.2	1.8	24	1080	90	77	68
2 x 35	7	7.4	1.2	1.8	27	1370	108	94	84
2 x 50	19	8.8	1.4	1.8	30	1770	128	112	101
2 x 70	19	10.6	1.4	1.9	34	2350	157	138	128
2 x 95	19	12.4	1.6	2.0	39	3180	188	167	156
2 x 120	37	14.0	1.6	2.1	42	3850	214	191	181
2 x 150	37	15.5	1.8	2.3	46	4680	239	214	206
2 x 185	37	17.4	2.0	2.4	52	5820	270	244	237
2 x 240	61	20.3	2.2	2.6	59	7520	313	285	281
2 x 300	61	22.7	2.4	2.8	65	9360	350	322	319
2 x 400	61	25.4	2.6	3.0	72	11700	394	364	365
2 x 500	61	28.8	2.8	3.2	80	14780	439	410	413

\*Overall Diameter Tolerance Range: [-2% , +6%]



Conductor : Round Stranded Copper  
 Insulation : Extruded PVC Material  
 Shield : Copper Tape Screen  
 Oversheath : Extruded Material (PVC or PE)

3-Cores CU/PVC/CUT/Sheathed 600/1000 V Cables as per IEC 60502-1							Continuous Current Rating		
Nominal Area	Number of Strands	Approx Conductor Diameter	Nominal Insulation Thickness	Nominal Outer Sheath Thickness	Approx. Overall Diameter*	Approx. Cable Weight	Ground	Duct [Gd]	Free Air
							Amps	Amps	Amps
mm	No.	mm	mm	mm	mm	kg/km			
3 x 1.5	7	1.6	0.8	1.8	14	270	16	14	11
3 x 2.5	7	2.0	0.8	1.8	15	320	21	18	15
3 x 4	7	2.6	1.0	1.8	17	430	28	24	20
3 x 6	7	3.1	1.0	1.8	18	520	35	29	25
3 x 10	7	4.0	1.0	1.8	20	700	46	39	34
3 x 16	7	5.0	1.0	1.8	22	940	60	50	45
3 x 25	7	6.3	1.2	1.8	26	1340	77	66	60
3 x 35	7	7.4	1.2	1.8	28	1570	91	78	71
3 x 50	19	8.8	1.4	1.9	32	2050	107	94	87
3 x 70	19	10.6	1.4	2.0	37	2790	131	115	109
3 x 95	19	12.4	1.6	2.1	42	3740	157	140	134
3 x 120	37	14.0	1.6	2.2	45	4550	178	159	155
3 x 150	37	15.5	1.8	2.4	50	5590	199	179	175
3 x 185	37	17.4	2.0	2.5	55	6900	225	204	201
3 x 240	61	20.3	2.2	2.7	63	8970	259	237	238
3 x 300	61	22.7	2.4	2.9	70	11110	290	268	271
3 x 400	61	25.4	2.6	3.2	77	14010	325	302	308
3 x 500	61	28.8	2.8	3.4	86	17740	361	339	349

\*Overall Diameter Tolerance Range: [-2% , +6%]

## Multicore (3½ & 4 Cores) - Copper Conductor, PVC Insulated CU Shielded Cables

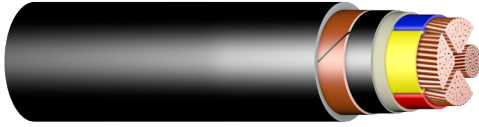

Conductor : Round / Sectoral Stranded Copper  
 Insulation : Extruded PVC Material  
 Shield : Copper Tape Screen  
 Oversheath : Extruded Material (PVC or PE)

3½ Cores CU/PVC/CUT/Sheathed 600/1000 V Cables as per IEC 60502-1							Continuous Current Rating		
Nominal Area	Number of Strands	Approx Conductor Diameter	Nominal Insulation Thickness	Nominal Outer Sheath Thickness	Approx. Overall Diameter**	Approx. Cable Weight	Ground	Duct [Gd]	Free Air
							Amps	Amps	Amps
mm	No.	mm	mm	mm	mm	kg/km			
3x16+10	7 / 7	5 / 4	1.0 / 1.0	1.8	23	1070	60	51	45
3x25+16	7 / 7	6.3 / 5	1.2 / 1.0	1.8	27	1530	77	66	60
3x35+16	7 / 7	6.6 / 5	1.2 / 1.0	1.8	27	1670	90	77	70
3x50+25	19 / 7	7.5 / 6.3	1.4 / 1.2	1.9	31	2230	106	92	85
3x70+35	19 / 7	9.1 / 7.4	1.4 / 1.2	2.0	35	3040	130	114	106
3x95+50	19 / 19	11 / 8.8	1.6 / 1.4	2.2	40	4080	155	138	131
3x120+70	37 / 19	12.2 / 10.6	1.6 / 1.4	2.3	43	5090	176	156	150
3x150+70	37 / 19	13.8 / 10.6	1.8 / 1.4	2.4	47	6070	197	176	171
3x185+95	37 / 19	15.1 / 12.4	2.0 / 1.6	2.6	52	7570	222	201	196
3x240+120	61 / 37	17.6 / 14	2.2 / 1.6	2.8	58	9750	256	233	230
3x300+150	61 / 37	19.8 / 15.5	2.4 / 1.8	3.0	64	12040	287	263	262
3x400+185	61 / 37	22.2 / 17.4	2.6 / 2.0	3.2	72	15240	322	298	300
3x500+240	61 / 61	26.3 / 20.3	2.8 / 2.2	3.5	80	19250	361	337	343

\*Sectoral Shape for conductor size > 25 mm<sup>2</sup>

\*\*Overall Diameter Tolerance Range: [-2% , +6%]

[Ph]: Phase [Ne]: Neutral

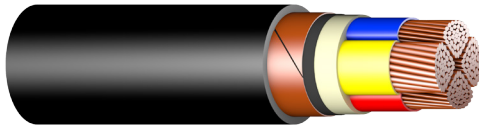

Conductor : Round / Sectoral Stranded Copper  
 Insulation : Extruded PVC Material  
 Shield : Copper Tape Screen  
 Oversheath : Extruded Material (PVC or PE)

4-Cores CU/PVC/CUT/Sheathed 600/1000 V Cables as per IEC 60502-1							Continuous Current Rating		
Nominal Area	Number of Strands	Approx Conductor Diameter	Nominal Insulation Thickness	Nominal Outer Sheath Thickness	Approx. Overall Diameter**	Approx. Cable Weight	Ground	Duct [Gd]	Free Air
							Amps	Amps	Amps
mm	No.	mm	mm	mm	mm	kg/km			
4 x 1.5	7	1.6	0.8	1.8	15	300	17	14	11
4 x 2.5	7	2.0	0.8	1.8	16	370	22	18	15
4 x 4	7	2.6	1.0	1.8	18	510	28	24	20
4 x 6	7	3.1	1.0	1.8	19	620	35	30	25
4 x 10	7	4.0	1.0	1.8	21	850	47	39	34
4 x 16	7	5.0	1.0	1.8	24	1150	60	51	46
4 x 25	7	6.3	1.2	1.8	28	1670	78	67	61
4 x 35	7	6.6	1.2	1.8	28	1860	90	78	71
4 x 50	19	7.5	1.4	2.0	33	2490	106	93	86
4 x 70	19	9.1	1.4	2.1	36	3370	130	114	107
4 x 95	19	11.0	1.6	2.3	41	4550	156	138	131
4 x 120	37	12.2	1.6	2.4	45	5590	177	158	152
4 x 150	37	13.8	1.8	2.5	50	6840	198	178	174
4 x 185	37	15.1	2.0	2.7	55	8500	223	202	198
4 x 240	61	17.6	2.2	2.9	61	10950	257	235	233
4 x 300	61	19.8	2.4	3.1	67	13540	288	266	265
4 x 400	61	22.2	2.6	3.4	76	17220	324	302	304
4 x 500	61	26.3	2.8	3.7	84	21700	363	339	347

\*Sectoral Shape for conductor size > 25 mm<sup>2</sup>

\*\*Overall Diameter Tolerance Range: [-2% , +6%]



## Multicore (5 Cores) - Copper Conductor, PVC Insulated CU Shielded Cables

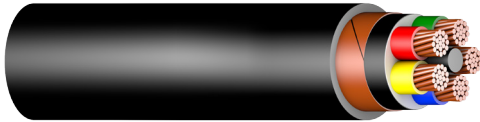

Conductor : Round Stranded Copper  
 Insulation : Extruded PVC Material  
 Shield : Copper Tape Screen  
 Oversheath : Extruded Material (PVC or PE)

5-Cores CU/PVC/CUT/Sheathed 600/1000 V Cables as per IEC 60502-1							Continuous Current Rating		
Nominal Area	Number of Strands	Approx Conductor Diameter	Nominal Insulation Thickness	Nominal Outer Sheath Thickness	Approx. Overall Diameter*	Approx. Cable Weight	Ground	Duct [Gd]	Free Air
							Amps	Amps	Amps
mm	No.	mm	mm	mm	mm	kg/km			
5 x 1.5	7	1.6	0.8	1.8	15	350	17	14	11
5 x 2.5	7	2.0	0.8	1.8	17	430	22	18	15
5 x 4	7	2.6	1.0	1.8	19	600	28	24	20
5 x 6	7	3.1	1.0	1.8	21	740	35	30	26
5 x 10	7	4.0	1.0	1.8	23	1010	47	40	35
5 x 16	7	5.0	1.0	1.8	26	1390	61	52	47
5 x 25	7	6.3	1.2	1.8	30	2030	78	68	63
5 x 35	7	7.4	1.2	1.9	34	2470	94	82	77
5 x 50	19	8.8	1.4	2.1	39	3310	111	98	94
5 x 70	19	10.6	1.4	2.2	44	4470	136	121	118
5 x 95	19	12.4	1.6	2.4	51	6110	163	147	145
5 x 120	37	14.0	1.6	2.5	56	7460	185	168	169
5 x 150	37	15.5	1.8	2.7	61	9150	207	189	191
5 x 185	37	17.4	2.0	2.9	68	11350	234	215	220
5 x 240	61	20.3	2.2	3.1	77	14680	270	251	261
5 x 300	61	22.7	2.4	3.4	86	18340	302	283	296
5 x 400	61	25.4	2.6	3.7	95	23150	339	320	338
5 x 500	61	28.8	2.8	4.0	106	29380	378	359	383

\*Overall Diameter Tolerance Range: [-2% , +6%]

## Single Core - Aluminium Conductor, PVC Insulated CU Shielded Cables

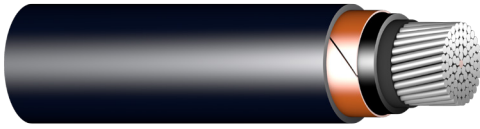

Conductor : Round Stranded Aluminium  
 Insulation : Extruded PVC Material  
 Shield : Copper Tape Screen  
 Oversheath : Extruded Material (PVC or PE)

**1-Core AL/PVC/CUT/Sheathed 600/1000 V Cables as per IEC 60502-1**

Nominal Area	Number of Strands	Approx Conductor Diameter	Nominal Insulation Thickness	Nominal Outer Sheath Thickness	Approx. Overall Diameter*	Approx. Cable Weight
mm	No.	mm	mm	mm	mm	kg/km
1 x 10	7	3.9	1.0	1.4	12	180
1 x 16	7	4.7	1.0	1.4	12	210
1 x 25	7	6.3	1.2	1.4	14	280
1 x 35	7	7.4	1.2	1.4	15	340
1 x 50	19	8.8	1.4	1.4	17	410
1 x 70	19	10.6	1.4	1.5	19	520
1 x 95	19	12.4	1.6	1.5	21	660
1 x 120	37	14	1.6	1.6	23	770
1 x 150	37	15.5	1.8	1.7	25	920
1 x 185	37	17.4	2.0	1.7	28	1100
1 x 240	61	19.9	2.2	1.8	31	1370
1 x 300	61	22.2	2.4	1.9	34	1650
1 x 400	61	25.2	2.6	2.0	38	2070
1 x 500	61	28.6	2.8	2.1	42	2520
1 x 630	91	32.6	2.8	2.2	46	3110
1 x 800	91	36.7	2.8	2.4	51	3850

\*Overall Diameter Tolerance Range: [-2% , +6%]

**Continuous Current Rating**

Nominal Area	Trefoil [Gd]	Trefoil in One Duct [Gd]	Trefoil in ThreeDucts [Gd]	Flat Touching [Gd]	Flat Spaced [Gd]	Flat Spaced in Three Ducts [Gd]	Trefoil [Air]	Flat Spaced [Air]	Flat Touching [Air]
mm	Amps	Amps	Amps	Amps	Amps	Amps	Amps	Amps	Amps
1 x 10	38	36	37	39	40	36	29	37	30
1 x 16	49	46	47	50	51	46	38	48	39
1 x 25	63	59	61	65	66	60	51	65	52
1 x 35	76	71	73	77	79	71	62	79	64
1 x 50	90	84	87	91	93	85	76	96	78
1 x 70	110	103	107	112	114	104	96	122	99
1 x 95	131	123	127	134	136	124	118	149	121
1 x 120	149	141	146	152	155	142	138	173	142
1 x 150	167	158	162	170	174	159	157	197	162
1 x 185	190	180	186	194	197	182	185	230	190
1 x 240	220	209	216	224	229	212	220	273	227
1 x 300	248	237	246	253	259	241	254	315	262
1 x 400	283	272	285	289	296	277	298	368	308
1 x 500	323	311	327	330	339	318	349	430	360
1 x 630	366	353	373	374	386	363	407	503	419
1 x 800	411	397	426	420	437	413	468	581	482

- When cables are arranged in spaced at formation they are spaced by one cable diameter.



## Multicore (2 & 3 Cores) - Aluminium Conductor, PVC Insulated CU Shielded Cables

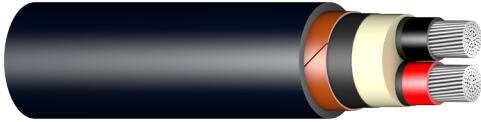

Conductor : Round Stranded Aluminium  
 Insulation : Extruded PVC Material  
 Shield : Copper Tape Screen  
 Oversheath : Extruded Material (PVC or PE)

2-Cores AL/PVC/CUT/Sheathed 600/1000 V Cables as per IEC 60502-1							Continuous Current Rating		
Nominal Area	Number of Strands	Approx Conductor Diameter	Nominal Insulation Thickness	Nominal Outer Sheath Thickness	Approx. Overall Diameter*	Approx. Cable Weight	Ground	Duct [Gd]	Free Air
							Amps	Amps	Amps
mm	No.	mm	mm	mm	mm	kg/km			
2 x 10	7	3.9	1.0	1.8	18	440	41	35	29
2 x 16	7	4.7	1.0	1.8	20	540	53	46	39
2 x 25	7	6.3	1.2	1.8	24	760	70	60	53
2 x 35	7	7.4	1.2	1.8	26	920	84	72	64
2 x 50	19	8.8	1.4	1.8	29	1180	99	86	78
2 x 70	19	10.6	1.4	1.9	33	1510	122	107	99
2 x 95	19	12.4	1.6	2.0	38	2010	146	129	121
2 x 120	37	14	1.6	2.1	42	2380	167	148	141
2 x 150	37	15.5	1.8	2.3	46	2870	186	167	160
2 x 185	37	17.4	2.0	2.4	51	3560	211	191	184
2 x 240	61	19.9	2.2	2.6	57	4480	245	223	218
2 x 300	61	22.2	2.4	2.8	64	5510	276	254	251
2 x 400	61	25.2	2.6	3.0	71	6840	316	293	293
2 x 500	61	28.6	2.8	3.2	79	8520	360	335	339

\*Overall Diameter Tolerance Range: [-2% , +6%]

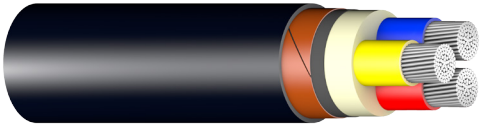

Conductor : Round Stranded Aluminium  
 Insulation : Extruded PVC Material  
 Shield : Copper Tape Screen  
 Oversheath : Extruded Material (PVC or PE)

3-Cores AL/PVC/CUT/Sheathed 600/1000 V Cables as per IEC 60502-1							Continuous Current Rating		
Nominal Area	Number of Strands	Approx Conductor Diameter	Nominal Insulation Thickness	Nominal Outer Sheath Thickness	Approx. Overall Diameter*	Approx. Cable Weight	Ground	Duct [Gd]	Free Air
							Amps	Amps	Amps
mm	No.	mm	mm	mm	mm	kg/km			
3 x 10	7	3.9	1.0	1.8	19	500	35	30	26
3 x 16	7	4.7	1.0	1.8	21	610	46	39	34
3 x 25	7	6.3	1.2	1.8	25	870	60	51	46
3 x 35	7	7.4	1.2	1.8	28	940	70	60	55
3 x 50	19	8.8	1.4	1.9	32	1190	83	73	67
3 x 70	19	10.6	1.4	2.0	37	1570	102	90	85
3 x 95	19	12.4	1.6	2.1	42	2030	122	109	104
3 x 120	37	14	1.6	2.2	45	2390	139	124	121
3 x 150	37	15.5	1.8	2.4	50	2930	156	140	137
3 x 185	37	17.4	2.0	2.5	55	3560	176	160	158
3 x 240	61	19.9	2.2	2.7	62	4520	204	187	187
3 x 300	61	22.2	2.4	2.9	69	5490	231	212	215
3 x 400	61	25.2	2.6	3.2	77	6830	263	245	250
3 x 500	61	28.6	2.8	3.4	86	8470	300	281	289

\*Overall Diameter Tolerance Range: [-2% , +6%]

## Multicore (3½ & 4 Cores) - Aluminium Conductor, PVC Insulated CU Shielded Cables

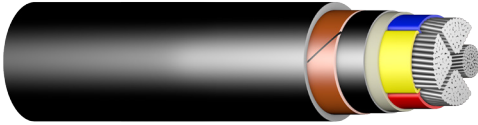

Conductor : Round / Sectoral Stranded Aluminium  
 Insulation : Extruded PVC Material  
 Shield : Copper Tape Screen  
 Oversheath : Extruded Material (PVC or PE)

3½ Cores AL/PVC/CUT/Sheathed 600/1000 V Cables as per IEC 60502-1							Continuous Current Rating		
Nominal Area	Number of Strands	Approx Conductor Diameter	Nominal Insulation Thickness	Nominal Outer Sheath Thickness	Approx. Overall Diameter**	Approx. Cable Weight	Ground	Duct [Gd]	Free Air
							Amps	Amps	Amps
mm	No.	mm	mm	mm	mm	kg/km			
3x16+10	7 / 7	4.7 / 3.9	1.0 / 1.0	1.8	22	690	46	39	34
3x25+16	7 / 7	6.3 / 4.7	1.2 / 1.0	1.8	26	960	60	51	46
3x35+16	7 / 7	6.5 / 4.7	1.2 / 1.0	1.8	27	940	70	60	54
3x50+25	7 / 7	7.5 / 6.3	1.4 / 1.2	1.9	31	1230	82	72	66
3x70+35	14 / 7	9.1 / 7.4	1.4 / 1.2	2.0	35	1580	101	89	83
3x95+50	19 / 19	10.8 / 8.8	1.6 / 1.4	2.2	40	2060	121	107	101
3x120+70	19 / 19	12.2 / 10.6	1.6 / 1.4	2.3	43	2490	137	122	117
3x150+70	37 / 19	13.5 / 10.6	1.8 / 1.4	2.4	47	2940	153	137	133
3x185+95	37 / 19	15.2 / 12.4	2.0 / 1.6	2.6	52	3610	174	157	154
3x240+120	37 / 37	17.5 / 14	2.2 / 1.6	2.8	58	4580	201	184	181
3x300+150	37 / 37	19.6 / 15.5	2.4 / 1.8	3.0	64	5550	227	209	208
3x400+185	61 / 37	22.5 / 17.4	2.6 / 2.0	3.2	72	6980	260	240	242
3x500+240	61 / 61	25.6 / 19.9	2.8 / 2.2	3.5	80	8620	296	276	281

\*Sectoral Shape for conductor size > 25 mm<sup>2</sup>

\*\*Overall Diameter Tolerance Range: [-2% , +6%]

[Ph]: Phase [Ne]: Neutral

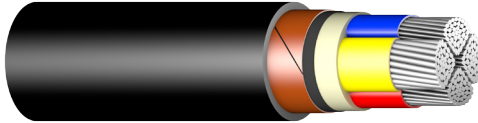

Conductor : Round / Sectoral Stranded Aluminium  
 Insulation : Extruded PVC Material  
 Shield : Copper Tape Screen  
 Oversheath : Extruded Material (PVC or PE)

4-Cores AL/PVC/CUT/Sheathed 600/1000 V Cables as per IEC 60502-1							Continuous Current Rating		
Nominal Area	Number of Strands	Approx Conductor Diameter	Nominal Insulation Thickness	Nominal Outer Sheath Thickness	Approx. Overall Diameter**	Approx. Cable Weight	Ground	Duct [Gd]	Free Air
							Amps	Amps	Amps
mm	No.	mm	mm	mm	mm	kg/km			
4 x 10	7	3.9	1.0	1.8	21	590	36	30	26
4 x 16	7	4.7	1.0	1.8	23	730	46	39	35
4 x 25	7	6.3	1.2	1.8	27	1050	60	52	47
4 x 35	7	6.5	1.2	1.8	28	1010	70	60	55
4 x 50	7	7.5	1.4	2.0	33	1350	82	72	66
4 x 70	14	9.1	1.4	2.1	36	1700	101	89	83
4 x 95	19	10.8	1.6	2.3	41	2240	121	107	102
4 x 120	19	12.2	1.6	2.4	45	2670	138	123	118
4 x 150	37	13.5	1.8	2.5	50	3220	154	139	135
4 x 185	37	15.2	2.0	2.7	55	3970	175	159	155
4 x 240	37	17.5	2.2	2.9	61	5000	202	185	183
4 x 300	37	19.6	2.4	3.1	67	6070	228	211	210
4 x 400	61	22.5	2.6	3.4	76	7690	261	243	245
4 x 500	61	25.6	2.8	3.7	84	9470	298	279	284

\*Sectoral Shape for conductor size > 25 mm<sup>2</sup>

\*\*Overall Diameter Tolerance Range: [-2% , +6%]



## Multicore (5 Cores) - Aluminium Conductor, PVC Insulated CU Shielded Cables



Conductor : Round Stranded Aluminium  
 Insulation : Extruded PVC Material  
 Shield : Copper Tape Screen  
 Oversheath : Extruded Material (PVC or PE)

5-Cores AL/PVC/CUT/Sheathed 600/1000 V Cables as per IEC 60502-1							Continuous Current Rating		
Nominal Area	Number of Strands	Approx Conductor Diameter	Nominal Insulation Thickness	Nominal Outer Sheath Thickness	Approx. Overall Diameter*	Approx. Cable Weight	Ground	Duct [Gd]	Free Air
							Amps	Amps	Amps
mm	No.	mm	mm	mm	mm	kg/km			
5 x 10	7	3.9	1.0	1.8	22	690	36	30	27
5 x 16	7	4.7	1.0	1.8	24	870	47	40	35
5 x 25	7	6.3	1.2	1.8	30	1270	61	53	49
5 x 35	7	7.4	1.2	1.9	34	1420	73	64	60
5 x 50	19	8.8	1.4	2.1	39	1890	86	76	73
5 x 70	19	10.6	1.4	2.2	44	2440	106	94	92
5 x 95	19	12.4	1.6	2.4	51	3260	127	114	113
5 x 120	37	14	1.6	2.5	56	3860	145	131	132
5 x 150	37	15.5	1.8	2.7	61	4720	162	147	149
5 x 185	37	17.4	2.0	2.9	68	5780	183	169	173
5 x 240	61	19.9	2.2	3.1	76	7280	213	198	205
5 x 300	61	22.2	2.4	3.4	85	8980	240	224	235
5 x 400	61	25.2	2.6	3.7	94	11190	275	258	273
5 x 500	61	28.6	2.8	4.0	106	13930	313	297	317

\*Overall Diameter Tolerance Range: [-2% , +6%]

## Single Core - Copper Conductor, XLPE Insulated Armored Cables

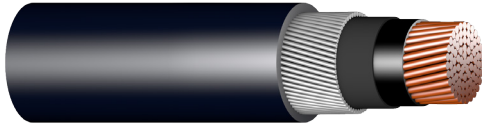

Conductor : Round Stranded Copper  
 Insulation : Extruded XLPE Material  
 Armor : Aluminium Wires  
 Oversheath : Extruded Material (PVC, LSF or PE)

1-Core CU/XLPE/AWA/Sheathed 600/1000 V Cables as per IEC 60502-1

Nominal Area	Number of Strands	Approx Conductor Diameter	Nominal Insulation Thickness	Nominal Armor wire Diameter	Nominal Outer Sheath Thickness	Approx. Overall Diameter*	Approx. Cable Weight
mm	No.	mm	mm	mm	mm	mm	kg/km
1 x 120	37	14.0	1.2	1.6	1.7	25	1610
1 x 150	37	15.5	1.4	1.6	1.7	27	1910
1 x 185	37	17.4	1.6	1.6	1.8	30	2330
1 x 240	61	20.3	1.7	1.6	1.9	33	2950
1 x 300	61	22.7	1.8	1.6	1.9	36	3590
1 x 400	61	25.4	2.0	2.0	2.1	40	4650
1 x 500	61	28.8	2.2	2.0	2.2	44	5800
1 x 630	61	30.4	2.4	2.0	2.3	47	7110
1 x 800	61	33.7	2.6	2.5	2.5	52	9120

\*Overall Diameter Tolerance Range: [-2% , +6%]

Continuous Current Rating

Nominal Area	Trefoil [Gd]	Trefoil in One Duct [Gd]	Trefoil in Three Ducts [Gd]	Flat Touching [Gd]	Flat Spaced [Gd]	Flat Spaced in Three Ducts [Gd]	Trefoil [Air]	Flat Spaced [Air]	Flat Touching [Air]
mm	Amps	Amps	Amps	Amps	Amps	Amps	Amps	Amps	Amps
1 x 120	239	227	233	242	237	217	295	352	301
1 x 150	267	253	262	269	260	240	336	395	341
1 x 185	298	284	295	299	286	264	386	444	391
1 x 240	340	325	339	339	318	295	453	508	456
1 x 300	376	360	378	372	343	319	514	561	514
1 x 400	410	393	415	399	356	333	574	596	566
1 x 500	447	430	458	431	379	354	644	650	629
1 x 630	482	464	500	460	398	374	705	694	682
1 x 800	497	480	527	468	404	382	745	719	711

- When cables are arranged in spaced at formation they are spaced by one cable diameter.



## Multicore (2 & 3 Cores) - Copper Conductor, XLPE Insulated Armored Cables

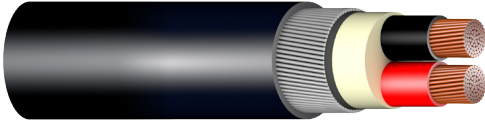

Conductor : Round Stranded Copper  
 Insulation : Extruded XLPE Material  
 Armor : Galvanized Steel Wires  
 Oversheath : Extruded Material (PVC, LSF or PE)

2-Cores CU/XLPE/SWA/Sheathed 600/1000 V Cables as per IEC 60502-1								Continuous Current Rating		
Nominal Area	Number of Strands	Approx Conductor Diameter	Nominal Insulation Thickness	Nominal Armor wire Diameter	Nominal Outer Sheath Thickness	Approx. Overall Diameter*	Approx. Cable Weight	Ground	Duct [Gd]	Free Air
								Amps	Amps	Amps
mm	No.	mm	mm	mm	mm	mm	kg/km			
2 x 1.5	7	1.6	0.7	0.8	1.8	14	350	25	21	21
2 x 2.5	7	2.0	0.7	0.8	1.8	15	400	33	27	28
2 x 4	7	2.6	0.7	0.8	1.8	16	470	42	36	37
2 x 6	7	3.1	0.7	0.8	1.8	17	550	53	45	47
2 x 10	7	4.0	0.7	1.3	1.8	20	840	71	60	66
2 x 16	7	5.0	0.7	1.3	1.8	22	1060	91	77	87
2 x 25	7	6.3	0.9	1.6	1.8	26	1570	118	101	116
2 x 35	7	7.4	0.9	1.6	1.8	28	1900	141	121	142
2 x 50	19	8.8	1.0	1.6	1.8	31	2330	167	144	172
2 x 70	19	10.6	1.1	1.6	2.0	36	3040	204	179	217
2 x 95	19	12.4	1.1	2.0	2.1	41	4160	244	215	266
2 x 120	37	14.0	1.2	2.0	2.2	45	4970	277	246	308
2 x 150	37	15.5	1.4	2.0	2.3	49	5890	309	276	349
2 x 185	37	17.4	1.6	2.5	2.5	55	7630	347	313	399
2 x 240	61	20.3	1.7	2.5	2.7	61	9500	398	362	469
2 x 300	61	22.7	1.8	2.5	2.8	67	11420	444	407	532
2 x 400	61	25.4	2.0	2.5	3.1	74	13990	494	456	603
2 x 500	61	28.8	2.2	3.2	3.3	83	18210	546	508	682

\*Overall Diameter Tolerance Range: [-2% , +6%]

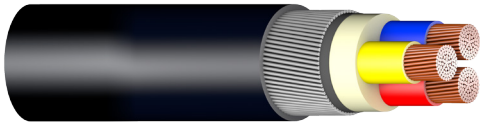

Conductor : Round Stranded Copper  
 Insulation : Extruded XLPE Material  
 Armor : Galvanized Steel Wires  
 Oversheath : Extruded Material (PVC, LSF or PE)

3-Cores CU/XLPE/SWA/Sheathed 600/1000 V Cables as per IEC 60502-1								Continuous Current Rating		
Nominal Area	Number of Strands	Approx Conductor Diameter	Nominal Insulation Thickness	Nominal Armor wire Diameter	Nominal Outer Sheath Thickness	Approx. Overall Diameter*	Approx. Cable Weight	Ground	Duct [Gd]	Free Air
								Amps	Amps	Amps
mm	No.	mm	mm	mm	mm	mm	kg/km			
3 x 1.5	7	1.6	0.7	0.8	1.8	15	370	21	18	18
3 x 2.5	7	2.0	0.7	0.8	1.8	16	440	28	23	24
3 x 4	7	2.6	0.7	0.8	1.8	17	520	36	30	32
3 x 6	7	3.1	0.7	0.8	1.8	18	620	45	37	41
3 x 10	7	4.0	0.7	1.3	1.8	21	960	60	50	56
3 x 16	7	5.0	0.7	1.3	1.8	23	1230	77	65	74
3 x 25	7	6.3	0.9	1.6	1.8	27	1830	99	84	99
3 x 35	7	7.4	0.9	1.6	1.8	30	2140	117	101	119
3 x 50	19	8.8	1.0	1.6	1.9	33	2650	138	120	144
3 x 70	19	10.6	1.1	2.0	2.0	39	3780	168	148	181
3 x 95	19	12.4	1.1	2.0	2.2	43	4800	200	177	221
3 x 120	37	14.0	1.2	2.0	2.3	47	5740	227	201	255
3 x 150	37	15.5	1.4	2.5	2.5	53	7340	252	227	289
3 x 185	37	17.4	1.6	2.5	2.6	58	8820	282	256	329
3 x 240	61	20.3	1.7	2.5	2.8	66	11090	322	294	385
3 x 300	61	22.7	1.8	2.5	3.0	72	13340	357	328	434
3 x 400	61	25.4	2.0	2.5	3.2	79	16420	394	364	488
3 x 500	61	28.8	2.2	3.2	3.5	90	21450	426	399	542

\*Overall Diameter Tolerance Range: [-2% , +6%]

## Multicore (3½ & 4 Cores) - Copper Conductor, XLPE Insulated Armored Cables

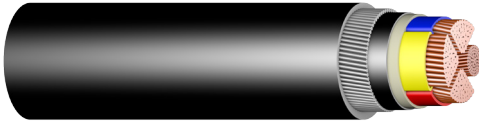

Conductor : Round / Sectoral Stranded Copper  
 Insulation : Extruded XLPE Material  
 Armor : Galvanized Steel Wires  
 Oversheath : Extruded Material (PVC, LSF or PE)

3½ Cores CU/XLPE/SWA/Sheathed 600/1000 V Cables as per IEC 60502-1								Continuous Current Rating		
Nominal Area*	Number of Strands	Approx Conductor Diameter	Nominal Insulation Thickness	Nominal Armor wire Diameter	Nominal Outer Sheath Thickness	Approx. Overall Diameter**	Approx. Cable Weight	Ground	Duct [Gd]	Free Air
								Amps	Amps	Amps
mm	No.	mm	mm	mm	mm	mm	kg/km			
3x16+10	7 / 7	5 / 4	0.7 / 0.7	1.3	1.8	24	1360	77	65	76
3x25+16	7 / 7	6.3 / 5	0.9 / 0.7	1.6	1.8	28	2030	99	85	101
3x35+16	7 / 7	6.6 / 5	0.9 / 0.7	1.6	1.8	28	2180	115	99	116
3x50+25	19 / 7	7.5 / 6.3	1.0 / 0.9	1.6	1.9	32	2770	137	119	141
3x70+35	19 / 7	9.1 / 7.4	1.1 / 0.9	2.0	2.1	37	3950	166	146	177
3x95+50	19 / 19	11 / 8.8	1.1 / 1.0	2.0	2.2	41	5000	199	175	216
3x120+70	37 / 19	12.2 / 10.6	1.2 / 1.1	2.0	2.4	45	6100	225	200	249
3x150+70	37 / 19	13.8 / 10.6	1.4 / 1.1	2.5	2.5	50	7660	251	224	283
3x185+95	37 / 19	15.1 / 12.4	1.6 / 1.1	2.5	2.7	55	9300	281	254	322
3x240+120	61 / 37	17.6 / 14	1.7 / 1.2	2.5	2.9	61	11600	321	293	375
3x300+150	61 / 37	19.8 / 15.5	1.8 / 1.4	2.5	3.0	66	13920	357	326	424
3x400+185	61 / 37	22.2 / 17.4	2.0 / 1.6	3.2	3.3	75	18120	395	365	482
3x500+240	61 / 61	26.3 / 20.3	2.2 / 1.7	3.2	3.6	83	22510	431	402	537

\*Sectoral Shape for conductor size > 25 mm<sup>2</sup>

\*\*Overall Diameter Tolerance Range: [-2% , +6%]

[Ph]: Phase [Ne]: Neutral

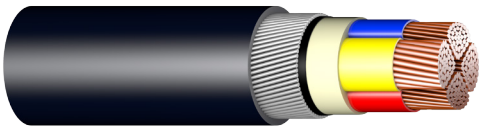

Conductor : Round / Sectoral Stranded Copper  
 Insulation : Extruded XLPE Material  
 Armor : Galvanized Steel Wires  
 Oversheath : Extruded Material (PVC, LSF or PE)

4-Cores CU/XLPE/SWA/Sheathed 600/1000 V Cables as per IEC 60502-1								Continuous Current Rating		
Nominal Area*	Number of Strands	Approx Conductor Diameter	Nominal Insulation Thickness	Nominal Armor wire Diameter	Nominal Outer Sheath Thickness	Approx. Overall Diameter**	Approx. Cable Weight	Ground	Duct [Gd]	Free Air
								Amps	Amps	Amps
mm	No.	mm	mm	mm	mm	mm	kg/km			
4 x 1.5	7	1.6	0.7	0.8	1.8	15	410	21	18	19
4 x 2.5	7	2.0	0.7	0.8	1.8	16	490	28	23	25
4 x 4	7	2.6	0.7	0.8	1.8	18	600	36	30	33
4 x 6	7	3.1	0.7	1.3	1.8	20	860	45	38	42
4 x 10	7	4.0	0.7	1.3	1.8	22	1110	60	50	58
4 x 16	7	5.0	0.7	1.6	1.8	25	1600	78	66	77
4 x 25	7	6.3	0.9	1.6	1.8	29	2190	100	86	102
4 x 35	7	6.6	0.9	1.6	1.9	30	2400	116	100	118
4 x 50	19	7.5	1.0	1.6	2.0	33	3020	137	119	142
4 x 70	19	9.1	1.1	2.0	2.2	39	4330	168	148	179
4 x 95	19	11.0	1.1	2.0	2.3	43	5500	200	177	219
4 x 120	37	12.2	1.2	2.5	2.5	48	7090	226	202	252
4 x 150	37	13.8	1.4	2.5	2.6	53	8490	253	227	288
4 x 185	37	15.1	1.6	2.5	2.8	57	10220	283	257	326
4 x 240	61	17.6	1.7	2.5	3.0	64	12870	323	296	381
4 x 300	61	19.8	1.8	2.5	3.2	69	15560	359	329	430
4 x 400	61	22.2	2.0	3.2	3.5	79	20360	398	369	488
4 x 500	61	26.3	2.2	3.2	3.8	87	25070	436	407	546

\*Sectoral Shape for conductor size > 25 mm<sup>2</sup>



\*\*Overall Diameter Tolerance Range: [-2% , +6%]

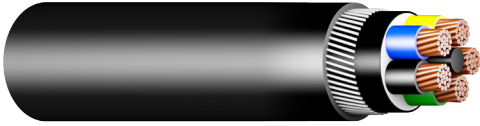

## Multicore (5 Cores) - Copper Conductor, XLPE Insulated Armored Cables



Conductor : Round Stranded Copper  
 Insulation : Extruded XLPE Material  
 Armor : Galvanized Steel Wires  
 Oversheath : Extruded Material (PVC, LSF or PE)

5-Cores CU/XLPE/SWA/Sheathed 600/1000 V Cables as per IEC 60502-1								Continuous Current Rating		
Nominal Area	Number of Strands	Approx Conductor Diameter	Nominal Insulation Thickness	Nominal Armor wire Diameter	Nominal Outer Sheath Thickness	Approx. Overall Diameter*	Approx. Cable Weight	Ground	Duct [Gd]	Free Air
								Amps	Amps	Amps
mm	No.	mm	mm	mm	mm	mm	kg/km			
5 x 1.5	7	1.6	0.7	0.8	1.8	16	460	22	18	19
5 x 2.5	7	2.0	0.7	0.8	1.8	17	560	28	24	25
5 x 4	7	2.6	0.7	1.3	1.8	20	830	37	31	34
5 x 6	7	3.1	0.7	1.3	1.8	21	980	46	38	43
5 x 10	7	4.0	0.7	1.3	1.8	24	1290	61	52	59
5 x 16	7	5.0	0.7	1.6	1.8	27	1860	79	67	79
5 x 25	7	6.3	0.9	1.6	1.8	32	2580	101	88	106
5 x 35	7	7.4	0.9	1.6	1.9	35	3090	121	105	129
5 x 50	19	8.8	1.0	2.0	2.1	41	4250	143	125	158
5 x 70	19	10.6	1.1	2.0	2.3	46	5620	174	154	197
5 x 95	19	12.4	1.1	2.5	2.4	53	7700	208	186	243
5 x 120	37	14.0	1.2	2.5	2.6	58	9320	234	211	279
5 x 150	37	15.5	1.4	2.5	2.8	64	11060	260	237	316
5 x 185	37	17.4	1.6	2.5	3.0	71	13540	290	266	359
5 x 240	61	20.3	1.7	2.5	3.2	79	17030	329	304	418
5 x 300	61	22.7	1.8	3.2	3.4	89	21760	358	335	468
5 x 400	61	25.4	2.0	3.2	3.8	98	26950	391	367	521
5 x 500	61	28.8	2.2	3.2	4.1	109	33430	423	401	578

\*Overall Diameter Tolerance Range: [-2% , +6%]

## Single Core - Aluminium Conductor, XLPE Insulated Armored Cables

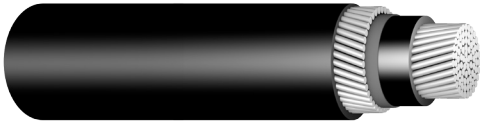

Conductor : Round Stranded Aluminium  
 Insulation : Extruded XLPE Material  
 Armor : Aluminium Wires  
 Oversheath : Extruded Material (PVC, LSF or PE)

**1-Core AL/XLPE/AWA/Sheathed 600/1000 V Cables as per IEC 60502-1**

Nominal Area	Number of Strands	Approx Conductor Diameter	Nominal Insulation Thickness	Nominal Armor wire Diameter	Nominal Outer Sheath Thickness	Approx. Overall Diameter*	Approx. Cable Weight
mm	No.	mm	mm	mm	mm	mm	kg/km
1 x 120	37	14	1.2	1.6	1.7	25	890
1 x 150	37	15.5	1.4	1.6	1.7	27	1030
1 x 185	37	17.4	1.6	1.6	1.8	30	1220
1 x 240	61	19.9	1.7	1.6	1.9	33	1480
1 x 300	61	22.2	1.8	1.6	1.9	35	1730
1 x 400	61	25.2	2.0	2.0	2.1	40	2270
1 x 500	61	28.6	2.2	2.0	2.2	44	2730
1 x 630	91	32.6	2.4	2.0	2.3	49	3360
1 x 800	91	36.7	2.6	2.5	2.5	55	4330

\*Overall Diameter Tolerance Range: [-2% , +6%]

**Continuous Current Rating**

Nominal Area	Trefoil [Gd]	Trefoil in One Duct [Gd]	Trefoil in Three Ducts [Gd]	Flat Touching [Gd]	Flat Spaced [Gd]	Flat Spaced in Three Ducts [Gd]	Trefoil [Air]	Flat Spaced [Air]	Flat Touching [Air]
mm	Amps	Amps	Amps	Amps	Amps	Amps	Amps	Amps	Amps
1 x 120	187	178	183	190	189	173	231	281	237
1 x 150	209	198	205	212	209	193	263	317	269
1 x 185	236	225	233	238	233	215	305	361	311
1 x 240	271	259	269	273	262	244	360	417	366
1 x 300	303	289	302	303	288	268	410	466	415
1 x 400	338	324	338	334	308	288	472	513	472
1 x 500	377	363	379	370	334	313	542	571	537
1 x 630	418	403	426	405	360	339	618	633	607
1 x 800	444	430	458	425	377	356	676	677	656

- When cables are arranged in spaced at formation they are spaced by one cable diameter.



## Multicore (2 & 3 Cores) - Aluminium Conductor, XLPE Insulated Armored Cables

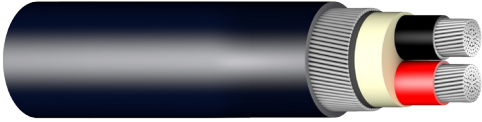

Conductor : Round Stranded Aluminium  
 Insulation : Extruded XLPE Material  
 Armor : Galvanized Steel Wires  
 Oversheath : Extruded Material (PVC, LSF or PE)

2-Cores AL/XLPE/SWA/Sheathed 600/1000 V Cables as per IEC 60502-1								Continuous Current Rating		
Nominal Area	Number of Strands	Approx Conductor Diameter	Nominal Insulation Thickness	Nominal Armor wire Diameter	Nominal Outer Sheath Thickness	Approx. Overall Diameter*	Approx. Cable Weight	Ground	Duct [Gd]	Free Air
								Amps	Amps	Amps
mm	No.	mm	mm	mm	mm	mm	kg/km			
2 x 10	7	3.9	0.7	1.3	1.8	19	680	54	46	50
2 x 16	7	4.7	0.7	1.3	1.8	21	800	70	59	66
2 x 25	7	6.3	0.9	1.6	1.8	25	1230	91	78	89
2 x 35	7	7.4	0.9	1.6	1.8	28	1440	109	94	110
2 x 50	19	8.8	1.0	1.6	1.8	31	1720	130	112	133
2 x 70	19	10.6	1.1	1.6	2.0	35	2190	158	139	167
2 x 95	19	12.4	1.1	2.0	2.1	40	2990	190	167	206
2 x 120	37	14	1.2	2.0	2.2	44	3500	216	191	239
2 x 150	37	15.5	1.4	2.0	2.3	48	4060	241	215	271
2 x 185	37	17.4	1.6	2.5	2.5	54	5330	272	246	312
2 x 240	61	19.9	1.7	2.5	2.7	60	6430	315	285	368
2 x 300	61	22.2	1.8	2.5	2.8	66	7550	353	323	421
2 x 400	61	25.2	2.0	2.5	3.1	73	9090	401	370	487
2 x 500	61	28.6	2.2	3.2	3.3	83	11890	454	423	565

\*Overall Diameter Tolerance Range: [-2% , +6%]

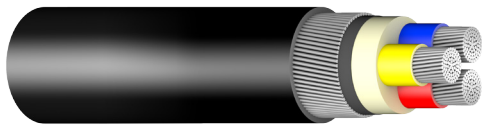

Conductor : Round Stranded Aluminium  
 Insulation : Extruded XLPE Material  
 Armor : Galvanized Steel Wires  
 Oversheath : Extruded Material (PVC, LSF or PE)

3-Cores AL/XLPE/SWA/Sheathed 600/1000 V Cables as per IEC 60502-1								Continuous Current Rating		
Nominal Area	Number of Strands	Approx Conductor Diameter	Nominal Insulation Thickness	Nominal Armor wire Diameter	Nominal Outer Sheath Thickness	Approx. Overall Diameter*	Approx. Cable Weight	Ground	Duct [Gd]	Free Air
								Amps	Amps	Amps
mm	No.	mm	mm	mm	mm	mm	kg/km			
3 x 10	7	3.9	0.7	1.3	1.8	20	740	46	38	43
3 x 16	7	4.7	0.7	1.3	1.8	22	880	59	49	56
3 x 25	7	6.3	0.9	1.6	1.8	27	1350	77	65	77
3 x 35	7	7.4	0.9	1.6	1.8	30	1490	90	78	92
3 x 50	19	8.8	1.0	1.6	1.9	33	1790	107	93	111
3 x 70	19	10.6	1.1	2.0	2.0	39	2560	131	115	141
3 x 95	19	12.4	1.1	2.0	2.2	43	3090	156	138	172
3 x 120	37	14	1.2	2.0	2.3	47	3590	177	158	199
3 x 150	37	15.5	1.4	2.5	2.5	53	4680	198	178	226
3 x 185	37	17.4	1.6	2.5	2.6	58	5480	223	202	260
3 x 240	61	19.9	1.7	2.5	2.8	65	6620	257	235	305
3 x 300	61	22.2	1.8	2.5	3.0	71	7690	288	265	348
3 x 400	61	25.2	2.0	2.5	3.2	79	9210	325	301	401
3 x 500	61	28.6	2.2	3.2	3.5	89	12190	361	338	456

\*Overall Diameter Tolerance Range: [-2% , +6%]

## Multicore (3½ & 4 Cores) - Aluminium Conductor, XLPE Insulated Armored Cables

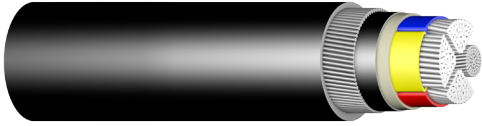

Conductor : Round / Sectoral Stranded Aluminium  
 Insulation : Extruded XLPE Material  
 Armor : Galvanized Steel Wires  
 Oversheath : Extruded Material (PVC, LSF or PE)

3½ Cores AL/XLPE/SWA/Sheathed 600/1000 V Cables as per IEC 60502-1								Continuous Current Rating		
Nominal Area*	Number of Strands	Approx Conductor Diameter	Nominal Insulation Thickness	Nominal Armor wire Diameter	Nominal Outer Sheath Thickness	Approx. Overall Diameter**	Approx. Cable Weight	Ground	Duct [Gd]	Free Air
								Amps	Amps	Amps
3x16+10	7 / 7	4.7 / 3.9	0.7 / 0.7	1.3	1.8	23	970	59	50	58
3x25+16	7 / 7	6.3 / 4.7	0.9 / 0.7	1.6	1.8	28	1440	77	66	78
3x35+16	7 / 7	6.5 / 4.7	0.9 / 0.7	1.6	1.8	28	1450	89	77	90
3x50+25	7 / 7	7.5 / 6.3	1.0 / 0.9	1.6	1.9	32	1770	106	92	109
3x70+35	14 / 7	9.1 / 7.4	1.1 / 0.9	2.0	2.1	37	2490	129	113	137
3x95+50	19 / 19	10.8 / 8.8	1.1 / 1.0	2.0	2.2	41	2980	155	136	168
3x120+70	19 / 19	12.2 / 10.6	1.2 / 1.1	2.0	2.4	45	3510	176	156	194
3x150+70	37 / 19	13.5 / 10.6	1.4 / 1.1	2.5	2.5	50	4530	196	176	221
3x185+95	37 / 19	15.2 / 12.4	1.6 / 1.1	2.5	2.7	55	5340	221	200	253
3x240+120	37 / 37	17.5 / 14	1.7 / 1.2	2.5	2.9	61	6430	255	232	297
3x300+150	37 / 37	19.6 / 15.5	1.8 / 1.4	2.5	3.0	66	7430	286	262	339
3x400+185	61 / 37	22.5 / 17.4	2.0 / 1.6	3.2	3.3	75	9860	323	298	393
3x500+240	61 / 61	25.6 / 19.9	2.2 / 1.7	3.2	3.6	83	11880	362	338	448

\*Sectoral Shape for conductor size > 25 mm<sup>2</sup>

\*\*Overall Diameter Tolerance Range: [-2% , +6%]

[Ph]: Phase [Ne]: Neutral

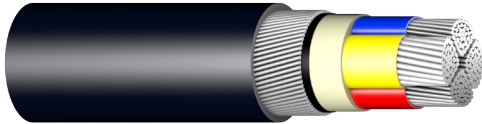

Conductor : Round / Sectoral Stranded Aluminium  
 Insulation : Extruded XLPE Material  
 Armor : Galvanized Steel Wires  
 Oversheath : Extruded Material (PVC, LSF or PE)

4-Cores AL/XLPE/SWA/Sheathed 600/1000 V Cables as per IEC 60502-1								Continuous Current Rating		
Nominal Area*	Number of Strands	Approx Conductor Diameter	Nominal Insulation Thickness	Nominal Armor wire Diameter	Nominal Outer Sheath Thickness	Approx. Overall Diameter**	Approx. Cable Weight	Ground	Duct [Gd]	Free Air
								Amps	Amps	Amps
4 x 10	7	3.9	0.7	1.3	1.8	21	850	46	39	44
4 x 16	7	4.7	0.7	1.6	1.8	24	1130	60	51	58
4 x 25	7	6.3	0.9	1.6	1.8	29	1560	78	67	79
4 x 35	7	6.5	0.9	1.6	1.9	30	1550	90	78	92
4 x 50	7	7.5	1.0	1.6	2.0	33	1880	106	92	110
4 x 70	14	9.1	1.1	2.0	2.2	39	2650	130	115	139
4 x 95	19	10.8	1.1	2.0	2.3	43	3190	156	138	170
4 x 120	19	12.2	1.2	2.5	2.5	48	4180	177	158	197
4 x 150	37	13.5	1.4	2.5	2.6	53	4860	198	178	225
4 x 185	37	15.2	1.6	2.5	2.8	57	5700	223	202	256
4 x 240	37	17.5	1.7	2.5	3.0	64	6930	257	235	302
4 x 300	37	19.6	1.8	2.5	3.2	69	8080	288	264	343
4 x 400	61	22.5	2.0	3.2	3.5	79	10820	325	301	397
4 x 500	61	25.6	2.2	3.2	3.8	87	12850	366	342	455

\*Sectoral Shape for conductor size > 25 mm<sup>2</sup>

\*\*Overall Diameter Tolerance Range: [-2% , +6%]



## Multicore (5 Cores) - Aluminium Conductor, XLPE Insulated Armored Cables

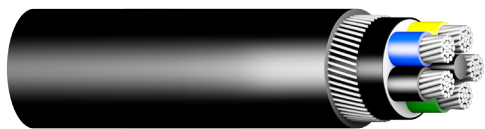

Conductor : Round Stranded Aluminium  
 Insulation : Extruded XLPE Material  
 Armor : Galvanized Steel Wires  
 Oversheath : Extruded Material (PVC, LSF or PE)

5-Cores AL/XLPE/SWA/Sheathed 600/1000 V Cables as per IEC 60502-1								Continuous Current Rating		
Nominal Area	Number of Strands	Approx Conductor Diameter	Nominal Insulation Thickness	Nominal Armor wire Diameter	Nominal Outer Sheath Thickness	Approx. Overall Diameter*	Approx. Cable Weight	Ground	Duct [Gd]	Free Air
								Amps	Amps	Amps
5 x 10	7	3.9	0.7	1.3	1.8	23	960			
5 x 16	7	4.7	0.7	1.6	1.8	26	1290			
5 x 25	7	6.3	0.9	1.6	1.8	31	1800			
5 x 35	7	7.4	0.9	1.6	1.9	35	2030			
5 x 50	19	8.8	1.0	2.0	2.1	41	2830			
5 x 70	19	10.6	1.1	2.0	2.3	46	3580			
5 x 95	19	12.4	1.1	2.5	2.4	53	4850			
5 x 120	37	14	1.2	2.5	2.6	58	5720			
5 x 150	37	15.5	1.4	2.5	2.8	64	6630			
5 x 185	37	17.4	1.6	2.5	3.0	71	7970			
5 x 240	61	19.9	1.7	2.5	3.2	78	9600			
5 x 300	61	22.2	1.8	3.2	3.4	87	12360			
5 x 400	61	25.2	2.0	3.2	3.8	97	14940			
5 x 500	61	28.6	2.2	3.2	4.1	108	17990			

\*Overall Diameter Tolerance Range: [-2% , +6%]

## Single Core - Copper Conductor, PVC Insulated Armored Cables

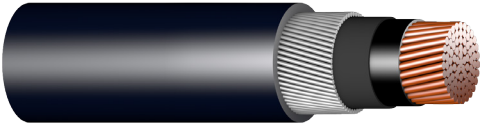

Conductor : Round Stranded Copper  
 Insulation : Extruded PVC Material  
 Armor : Aluminium Wires  
 Oversheath : Extruded Material (PVC or PE)

1-Core CU/PVC/AWA/Sheathed 600/1000 V Cables as per IEC 60502-1							
Nominal Area	Number of Strands	Approx Conductor Diameter	Nominal Insulation Thickness	Nominal Armor wire Diameter	Nominal Outer Sheath Thickness	Approx. Overall Diameter*	Approx. Cable Weight
mm	No.	mm	mm	mm	mm	mm	kg/km
1 x 120	37	14.0	1.6	1.6	1.7	26	1700
1 x 150	37	15.5	1.8	1.6	1.7	28	2010
1 x 185	37	17.4	2.0	1.6	1.8	31	2450
1 x 240	61	20.3	2.2	1.6	1.9	34	3110
1 x 300	61	22.7	2.4	2.0	2.0	38	3910
1 x 400	61	25.4	2.6	2.0	2.1	42	4880
1 x 500	61	28.8	2.8	2.0	2.2	46	6080
1 x 630	61	30.4	2.8	2.0	2.4	48	7360
1 x 800	61	33.7	2.8	2.5	2.5	53	9330

\*Overall Diameter Tolerance Range: [-2% , +6%]

Continuous Current Rating									
Nominal Area	Trefoil [Gd]	Trefoil in One Duct [Gd]	Trefoil in Three Ducts [Gd]	Flat Touching [Gd]	Flat Spaced [Gd]	Flat Spaced in Three Ducts [Gd]	Trefoil [Air]	Flat Spaced [Air]	Flat Touching [Air]
mm	Amps	Amps	Amps	Amps	Amps	Amps	Amps	Amps	Amps
1 x 120	190	180	187	192	187	172	181	215	185
1 x 150	211	201	207	213	205	189	206	241	209
1 x 185	236	225	233	236	224	208	236	270	239
1 x 240	269	257	267	267	248	230	276	306	277
1 x 300	293	280	296	287	259	242	310	330	307
1 x 400	322	309	327	312	277	260	349	361	343
1 x 500	350	337	360	336	294	276	390	393	380
1 x 630	375	362	393	357	308	290	423	416	409
1 x 800	385	372	408	363	314	297	447	436	427

- When cables are arranged in spaced flat formation they are spaced by one cable diameter.



## Multicore (2 & 3 Cores) - Copper Conductor, PVC Insulated Armored Cables

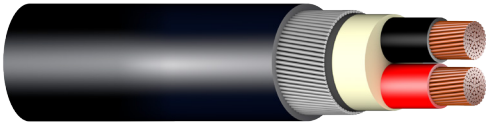

Conductor : Round Stranded Copper  
 Insulation : Extruded PVC Material  
 Armor : Galvanized Steel Wires  
 Oversheath : Extruded Material (PVC or PE)

2-Cores CU/PVC/SWA/Sheathed 600/1000 V Cables as per IEC 60502-1								Continuous Current Rating		
Nominal Area	Number of Strands	Approx Conductor Diameter	Nominal Insulation Thickness	Nominal Armor wire Diameter	Nominal Outer Sheath Thickness	Approx. Overall Diameter*	Approx. Cable Weight	Ground	Duct [Gd]	Free Air
								Amps	Amps	Amps
mm	No.	mm	mm	mm	mm	mm	kg/km			
2 x 1.5	7	1.6	0.8	0.8	1.8	15	370	20	17	13
2 x 2.5	7	2.0	0.8	0.8	1.8	15	430	26	22	18
2 x 4	7	2.6	1.0	0.8	1.8	17	540	33	28	23
2 x 6	7	3.1	1.0	1.3	1.8	19	760	42	36	30
2 x 10	7	4.0	1.0	1.3	1.8	21	930	55	47	41
2 x 16	7	5.0	1.0	1.3	1.8	23	1150	72	61	54
2 x 25	7	6.3	1.2	1.6	1.8	27	1700	92	80	71
2 x 35	7	7.4	1.2	1.6	1.8	29	2040	111	96	87
2 x 50	19	8.8	1.4	1.6	1.9	33	2550	131	114	106
2 x 70	19	10.6	1.4	2.0	2.0	38	3480	161	142	134
2 x 95	19	12.4	1.6	2.0	2.2	43	4500	191	170	163
2 x 120	37	14.0	1.6	2.0	2.3	46	5310	217	194	188
2 x 150	37	15.5	1.8	2.5	2.4	51	6660	242	219	214
2 x 185	37	17.4	2.0	2.5	2.6	57	8070	272	248	245
2 x 240	61	20.3	2.2	2.5	2.8	64	10050	312	286	288
2 x 300	61	22.7	2.4	2.5	2.9	70	12140	347	320	325
2 x 400	61	25.4	2.6	2.5	3.2	77	14790	385	358	368
2 x 500	61	28.8	2.8	3.2	3.4	86	19210	424	398	414

\*Overall Diameter Tolerance Range: [-2% , +6%]

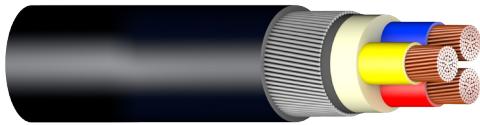

Conductor : Round Stranded Copper  
 Insulation : Extruded PVC Material  
 Armor : Galvanized Steel Wires  
 Oversheath : Extruded Material (PVC or PE)

3-Cores CU/PVC/SWA/Sheathed 600/1000 V Cables as per IEC 60502-1								Continuous Current Rating		
Nominal Area	Number of Strands	Approx Conductor Diameter	Nominal Insulation Thickness	Nominal Armor wire Diameter	Nominal Outer Sheath Thickness	Approx. Overall Diameter*	Approx. Cable Weight	Ground	Duct [Gd]	Free Air
								Amps	Amps	Amps
mm	No.	mm	mm	mm	mm	mm	kg/km			
3 x 1.5	7	1.6	0.8	0.8	1.8	15	400	17	14	11
3 x 2.5	7	2.0	0.8	0.8	1.8	16	470	22	18	15
3 x 4	7	2.6	1.0	1.3	1.8	19	740	28	24	20
3 x 6	7	3.1	1.0	1.3	1.8	20	840	35	30	26
3 x 10	7	4.0	1.0	1.3	1.8	22	1060	47	40	35
3 x 16	7	5.0	1.0	1.3	1.8	24	1350	61	52	46
3 x 25	7	6.3	1.2	1.6	1.8	29	1980	78	68	62
3 x 35	7	7.4	1.2	1.6	1.8	31	2290	92	80	74
3 x 50	19	8.8	1.4	1.6	2.0	35	2890	109	95	89
3 x 70	19	10.6	1.4	2.0	2.1	40	4020	133	117	112
3 x 95	19	12.4	1.6	2.0	2.2	45	5150	158	141	137
3 x 120	37	14.0	1.6	2.0	2.3	49	6060	179	161	158
3 x 150	37	15.5	1.8	2.5	2.5	55	7730	199	180	180
3 x 185	37	17.4	2.0	2.5	2.7	60	9310	222	202	204
3 x 240	61	20.3	2.2	2.5	2.9	68	11700	253	233	238
3 x 300	61	22.7	2.4	2.5	3.1	75	14120	280	259	268
3 x 400	61	25.4	2.6	3.2	3.4	83	18250	305	285	299
3 x 500	61	28.8	2.8	3.2	3.6	92	22500	332	312	333

\*Overall Diameter Tolerance Range: [-2% , +6%]

## Multicore (3½ & 4 Cores) - Copper Conductor, PVC Insulated Armored Cables



Conductor : Round / Sectoral Stranded Copper  
 Insulation : Extruded PVC Material  
 Armor : Galvanized Steel Wires  
 Oversheath : Extruded Material (PVC or PE)

3½ Cores CU/PVC/SWA/Sheathed 600/1000 V Cables as per IEC 60502-1								Continuous Current Rating		
Nominal Area*	Number of Strands	Approx Conductor Diameter	Nominal Insulation Thickness	Nominal Armor wire Diameter	Nominal Outer Sheath Thickness	Approx. Overall Diameter**	Approx. Cable Weight	Ground	Duct [Gd]	Free Air
								Amps	Amps	Amps
3x16+10	7 / 7	5 / 4	1.0 / 1.0	1.6	1.8	26	1650	61	53	47
3x25+16	7 / 7	6.3 / 5	1.2 / 1.0	1.6	1.8	30	2220	79	68	63
3x35+16	7 / 7	6.6 / 5	1.2 / 1.0	1.6	1.9	30	2370	91	79	73
3x50+25	19 / 7	7.5 / 6.3	1.4 / 1.2	2.0	2.0	35	3260	108	95	89
3x70+35	19 / 7	9.1 / 7.4	1.4 / 1.2	2.0	2.1	39	4200	132	116	110
3x95+50	19 / 19	11 / 8.8	1.6 / 1.4	2.0	2.3	44	5420	157	140	135
3x120+70	37 / 19	12.2 / 10.6	1.6 / 1.4	2.5	2.5	49	6980	178	160	156
3x150+70	37 / 19	13.8 / 10.6	1.8 / 1.4	2.5	2.6	52	8120	198	178	175
3x185+95	37 / 19	15.1 / 12.4	2.0 / 1.6	2.5	2.7	57	9800	222	202	200
3x240+120	61 / 37	17.6 / 14	2.2 / 1.6	2.5	2.9	63	12260	252	230	232
3x300+150	61 / 37	19.8 / 15.5	2.4 / 1.8	2.5	3.1	69	14790	280	257	263
3x400+185	61 / 37	22.2 / 17.4	2.6 / 2.0	3.2	3.4	79	19230	309	287	297
3x500+240	61 / 61	26.3 / 20.3	2.8 / 2.2	3.2	3.7	86	23630	336	315	331

\*Sectoral Shape for conductor size > 25 mm<sup>2</sup>

\*\*Overall Diameter Tolerance Range: [-2%, +6%]

[Ph]: Phase [Ne]: Neutral

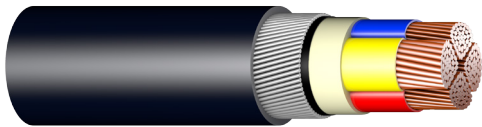

Conductor : Round / Sectoral Stranded Copper  
 Insulation : Extruded PVC Material  
 Armor : Galvanized Steel Wires  
 Oversheath : Extruded Material (PVC or PE)

4-Cores CU/PVC/SWA/Sheathed 600/1000 V Cables as per IEC 60502-1								Continuous Current Rating		
Nominal Area*	Number of Strands	Approx Conductor Diameter	Nominal Insulation Thickness	Nominal Armor wire Diameter	Nominal Outer Sheath Thickness	Approx. Overall Diameter**	Approx. Cable Weight	Ground	Duct [Gd]	Free Air
								Amps	Amps	Amps
4 x 1.5	7	1.6	0.8	0.8	1.8	16	450	17	14	12
4 x 2.5	7	2.0	0.8	0.8	1.8	17	540	22	19	16
4 x 4	7	2.6	1.0	1.3	1.8	20	830	29	24	21
4 x 6	7	3.1	1.0	1.3	1.8	21	980	36	30	26
4 x 10	7	4.0	1.0	1.3	1.8	24	1240	48	41	36
4 x 16	7	5.0	1.0	1.6	1.8	27	1750	61	53	48
4 x 25	7	6.3	1.2	1.6	1.8	31	2370	79	68	64
4 x 35	7	6.6	1.2	1.6	1.9	31	2590	92	79	73
4 x 50	19	7.5	1.4	2.0	2.1	37	3600	108	95	90
4 x 70	19	9.1	1.4	2.0	2.2	40	4590	132	117	111
4 x 95	19	11.0	1.6	2.5	2.4	46	6340	158	141	137
4 x 120	37	12.2	1.6	2.5	2.5	50	7540	178	160	157
4 x 150	37	13.8	1.8	2.5	2.7	55	8980	199	181	178
4 x 185	37	15.1	2.0	2.5	2.9	60	10870	223	203	202
4 x 240	61	17.6	2.2	2.5	3.1	66	13610	254	233	236
4 x 300	61	19.8	2.4	2.5	3.3	72	16450	282	260	266
4 x 400	61	22.2	2.6	3.2	3.6	83	21400	312	292	302
4 x 500	61	26.3	2.8	3.2	3.9	90	26330	340	319	336

\*Sectoral Shape for conductor size > 25 mm<sup>2</sup>



\*\*Overall Diameter Tolerance Range: [-2%, +6%]

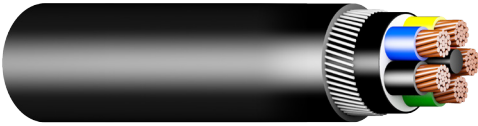

## Multicore (5 Cores) - Copper Conductor, PVC Insulated Armored Cables



Conductor : Round Stranded Copper  
 Insulation : Extruded PVC Material  
 Armor : Galvanized Steel Wires  
 Oversheath : Extruded Material (PVC or PE)

5-Cores CU/PVC/SWA/Sheathed 600/1000 V Cables as per IEC 60502-1								Continuous Current Rating		
Nominal Area	Number of Strands	Approx Conductor Diameter	Nominal Insulation Thickness	Nominal Armor wire Diameter	Nominal Outer Sheath Thickness	Approx. Overall Diameter*	Approx. Cable Weight	Ground	Duct [Gd]	Free Air
								Amps 	Amps 	Amps 
mm	No.	mm	mm	mm	mm	mm	kg/km			
5 x 1.5	7	1.6	0.8	0.8	1.8	17	510	17	14	12
5 x 2.5	7	2.0	0.8	0.8	1.8	18	600	22	19	16
5 x 4	7	2.6	1.0	1.3	1.8	21	950	29	25	21
5 x 6	7	3.1	1.0	1.3	1.8	23	1120	36	31	27
5 x 10	7	4.0	1.0	1.6	1.8	26	1600	48	41	37
5 x 16	7	5.0	1.0	1.6	1.8	29	2050	62	54	49
5 x 25	7	6.3	1.2	1.6	1.9	33	2830	80	69	65
5 x 35	7	7.4	1.2	2.0	2.0	38	3610	96	84	81
5 x 50	19	8.8	1.4	2.0	2.2	43	4620	113	100	97
5 x 70	19	10.6	1.4	2.0	2.3	48	5960	138	123	122
5 x 95	19	12.4	1.6	2.5	2.5	56	8290	163	148	150
5 x 120	37	14.0	1.6	2.5	2.7	61	9870	185	168	173
5 x 150	37	15.5	1.8	2.5	2.9	66	11800	204	187	194
5 x 185	37	17.4	2.0	2.5	3.0	73	14260	228	210	221
5 x 240	61	20.3	2.2	3.2	3.3	84	18980	256	238	256
5 x 300	61	22.7	2.4	3.2	3.6	92	23100	279	262	285
5 x 400	61	25.4	2.6	3.2	3.9	101	28420	304	287	318
5 x 500	61	28.8	2.8	3.2	4.2	113	35240	329	313	352

\*Overall Diameter Tolerance Range: [-2% , +6%]

## Single Core - Aluminium Conductor, PVC Insulated Armored Cables

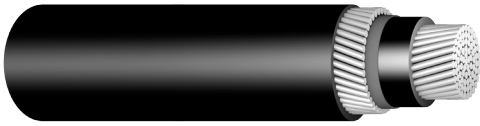

Conductor : Round Stranded Aluminium  
 Insulation : Extruded PVC Material  
 Armor : Aluminium Wires  
 Oversheath : Extruded Material (PVC or PE)

1-Core AL/PVC/AWA/Sheathed 600/1000 V Cables as per IEC 60502-1							
Nominal Area	Number of Strands	Approx Conductor Diameter	Nominal Insulation Thickness	Nominal Armor wire Diameter	Nominal Outer Sheath Thickness	Approx. Overall Diameter*	Approx. Cable Weight
mm	No.	mm	mm	mm	mm	mm	kg/km
1 x 120	37	14	1.6	1.6	1.7	26	980
1 x 150	37	15.5	1.8	1.6	1.7	28	1130
1 x 185	37	17.4	2	1.6	1.8	31	1350
1 x 240	61	19.9	2.2	1.6	1.9	34	1640
1 x 300	61	22.2	2.4	2.0	2.0	38	2050
1 x 400	61	25.2	2.6	2.0	2.1	41	2510
1 x 500	61	28.6	2.8	2.0	2.2	46	3010
1 x 630	91	32.6	2.8	2.0	2.4	50	3670
1 x 800	91	36.7	2.8	2.5	2.5	56	4620

\*Overall Diameter Tolerance Range: [-2% , +6%]

Continuous Current Rating									
Nominal Area	Trefoil [Gd]	Trefoil in One Duct [Gd]	Trefoil in Three Ducts [Gd]	Flat Touching [Gd]	Flat Spaced [Gd]	Flat Spaced in Three Ducts [Gd]	Trefoil [Air]	Flat Spaced [Air]	Flat Touching [Air]
mm	Amps	Amps	Amps	Amps	Amps	Amps	Amps	Amps	Amps
1 x 120	149	142	147	151	150	138	142	172	146
1 x 150	166	158	163	168	165	153	162	194	165
1 x 185	187	179	184	189	184	170	187	220	191
1 x 240	215	206	213	216	206	192	220	253	224
1 x 300	238	228	238	236	221	207	251	279	253
1 x 400	267	256	266	263	241	226	287	310	287
1 x 500	297	286	300	290	261	246	330	346	326
1 x 630	328	316	333	317	280	264	373	381	366
1 x 800	347	336	358	332	294	279	408	412	396

- When cables are arranged in spaced at formation they are spaced by one cable diameter.



## Multicore (2 & 3 Cores) - Aluminium Conductor, PVC Insulated Armored Cables

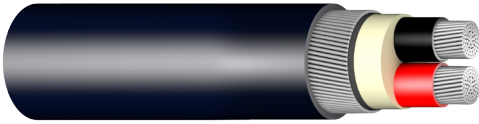

Conductor : Round Stranded Aluminium  
 Insulation : Extruded PVC Material  
 Armor : Galvanized Steel Wires  
 Oversheath : Extruded Material (PVC or PE)

2-Cores AL/PVC/SWA/Sheathed 600/1000 V Cables as per IEC 60502-1								Continuous Current Rating		
Nominal Area	Number of Strands	Approx Conductor Diameter	Nominal Insulation Thickness	Nominal Armor wire Diameter	Nominal Outer Sheath Thickness	Approx. Overall Diameter*	Approx. Cable Weight	Ground	Duct [Gd]	Free Air
								Amps	Amps	Amps
mm	No.	mm	mm	mm	mm	mm	kg/km			
2 x 10	7	3.9	1.0	1.3	1.8	20	770	42	36	31
2 x 16	7	4.7	1.0	1.3	1.8	22	900	55	47	41
2 x 25	7	6.3	1.2	1.6	1.8	27	1360	72	62	56
2 x 35	7	7.4	1.2	1.6	1.8	29	1580	86	75	68
2 x 50	19	8.8	1.4	1.6	1.9	33	1940	102	89	82
2 x 70	19	10.6	1.4	2.0	2.0	37	2620	125	110	104
2 x 95	19	12.4	1.6	2.0	2.2	42	3310	149	132	126
2 x 120	37	14	1.6	2.0	2.3	46	3810	169	151	147
2 x 150	37	15.5	1.8	2.5	2.4	51	4860	190	171	167
2 x 185	37	17.4	2.0	2.5	2.6	56	5770	214	194	192
2 x 240	61	19.9	2.2	2.5	2.8	62	6970	247	225	226
2 x 300	61	22.2	2.4	2.5	2.9	69	8260	277	255	258
2 x 400	61	25.2	2.6	2.5	3.2	76	9890	314	292	298
2 x 500	61	28.6	2.8	3.2	3.4	86	12880	355	333	345

\*Overall Diameter Tolerance Range: [-2% , +6%]

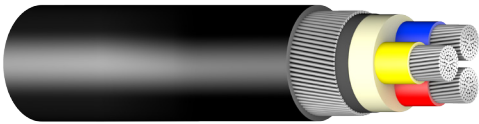

Conductor : Round Stranded Aluminium  
 Insulation : Extruded PVC Material  
 Armor : Galvanized Steel Wires  
 Oversheath : Extruded Material (PVC or PE)

3-Cores AL/PVC/SWA/Sheathed 600/1000 V Cables as per IEC 60502-1								Continuous Current Rating		
Nominal Area	Number of Strands	Approx Conductor Diameter	Nominal Insulation Thickness	Nominal Armor wire Diameter	Nominal Outer Sheath Thickness	Approx. Overall Diameter*	Approx. Cable Weight	Ground	Duct [Gd]	Free Air
								Amps	Amps	Amps
mm	No.	mm	mm	mm	mm	mm	kg/km			
3 x 10	7	3.9	1.0	1.3	1.8	21	850	36	30	27
3 x 16	7	4.7	1.0	1.3	1.8	23	1000	47	40	35
3 x 25	7	6.3	1.2	1.6	1.8	28	1520	61	52	48
3 x 35	7	7.4	1.2	1.6	1.8	31	1660	72	62	57
3 x 50	19	8.8	1.4	1.6	2.0	35	2020	84	74	69
3 x 70	19	10.6	1.4	2.0	2.1	40	2800	103	91	87
3 x 95	19	12.4	1.6	2.0	2.2	45	3440	123	110	107
3 x 120	37	14	1.6	2.0	2.3	49	3900	140	126	124
3 x 150	37	15.5	1.8	2.5	2.5	55	5070	156	142	141
3 x 185	37	17.4	2.0	2.5	2.7	60	5970	176	160	161
3 x 240	61	19.9	2.2	2.5	2.9	67	7220	203	186	189
3 x 300	61	22.2	2.4	2.5	3.1	74	8460	227	210	216
3 x 400	61	25.2	2.6	3.2	3.4	83	11070	254	237	247
3 x 500	61	28.6	2.8	3.2	3.6	92	13230	283	267	282

\*Overall Diameter Tolerance Range: [-2% , +6%]

## Multicore (3½ & 4 Cores) - Aluminium Conductor, PVC Insulated Armored Cables

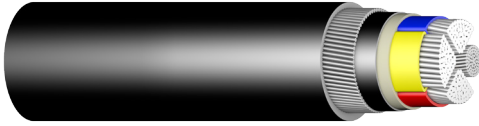

Conductor : Round / Sectoral Stranded Aluminium  
 Insulation : Extruded PVC Material  
 Armor : Galvanized Steel Wires  
 Oversheath : Extruded Material (PVC or PE)

3½ Cores AL/PVC/SWA/Sheathed 600/1000 V Cables as per IEC 60502-1								Continuous Current Rating		
Nominal Area*	Number of Strands	Approx Conductor Diameter	Nominal Insulation Thickness	Nominal Armor wire Diameter	Nominal Outer Sheath Thickness	Approx. Overall Diameter**	Approx. Cable Weight	Ground	Duct [Gd]	Free Air
								Amps	Amps	Amps
mm	No.	mm	mm	mm	mm	mm	kg/km			
3x16+10	7 / 7	4.7 / 3.9	1.0 / 1.0	1.6	1.8	25	1240	47	40	36
3x25+16	7 / 7	6.3 / 4.7	1.2 / 1.0	1.6	1.8	29	1620	61	53	48
3x35+16	7 / 7	6.5 / 4.7	1.2 / 1.0	1.6	1.9	30	1640	71	61	56
3x50+25	7 / 7	7.5 / 6.3	1.4 / 1.2	2.0	2.0	35	2260	84	74	69
3x70+35	14 / 7	9.1 / 7.4	1.4 / 1.2	2.0	2.1	39	2730	103	91	86
3x95+50	19 / 19	10.8 / 8.8	1.6 / 1.4	2.0	2.3	44	3400	122	109	105
3x120+70	19 / 19	12.2 / 10.6	1.6 / 1.4	2.5	2.5	49	4380	139	125	122
3x150+70	37 / 19	13.5 / 10.6	1.8 / 1.4	2.5	2.6	52	4990	155	140	137
3x185+95	37 / 19	15.2 / 12.4	2.0 / 1.6	2.5	2.7	57	5840	175	159	158
3x240+120	37 / 37	17.5 / 14	2.2 / 1.6	2.5	2.9	63	7080	201	184	185
3x300+150	37 / 37	19.6 / 15.5	2.4 / 1.8	2.5	3.1	69	8290	225	207	211
3x400+185	61 / 37	22.5 / 17.4	2.6 / 2.0	3.2	3.4	79	10960	254	236	243
3x500+240	61 / 61	25.6 / 19.9	2.8 / 2.2	3.2	3.7	86	12990	284	266	277

\*Sectoral Shape for conductor size > 25 mm<sup>2</sup>

\*\*Overall Diameter Tolerance Range: [-2%, +6%]

[Ph]: Phase [Ne]: Neutral

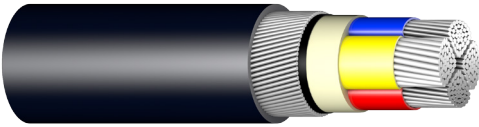

Conductor : Round / Sectoral Stranded Aluminium  
 Insulation : Extruded PVC Material  
 Armor : Galvanized Steel Wires  
 Oversheath : Extruded Material (PVC or PE)

4-Cores AL/PVC/SWA/Sheathed 600/1000 V Cables as per IEC 60502-1								Continuous Current Rating		
Nominal Area*	Number of Strands	Approx Conductor Diameter	Nominal Insulation Thickness	Nominal Armor wire Diameter	Nominal Outer Sheath Thickness	Approx. Overall Diameter**	Approx. Cable Weight	Ground	Duct [Gd]	Free Air
								Amps	Amps	Amps
mm	No.	mm	mm	mm	mm	mm	kg/km			
4 x 10	7	3.9	1.0	1.3	1.8	23	970	36	31	27
4 x 16	7	4.7	1.0	1.6	1.8	26	1290	47	41	37
4 x 25	7	6.3	1.2	1.6	1.8	30	1760	61	53	49
4 x 35	7	6.5	1.2	1.6	1.9	31	1750	71	62	57
4 x 50	7	7.5	1.4	2.0	2.1	37	2460	84	74	69
4 x 70	14	9.1	1.4	2.0	2.2	40	2910	103	91	87
4 x 95	19	10.8	1.6	2.5	2.4	46	4030	123	110	106
4 x 120	19	12.2	1.6	2.5	2.5	50	4620	140	125	123
4 x 150	37	13.5	1.8	2.5	2.7	55	5350	156	141	140
4 x 185	37	15.2	2.0	2.5	2.9	60	6350	176	160	159
4 x 240	37	17.5	2.2	2.5	3.1	66	7660	202	185	187
4 x 300	37	19.6	2.4	2.5	3.3	72	8970	227	209	213
4 x 400	61	22.5	2.6	3.2	3.6	83	11870	256	240	247
4 x 500	61	25.6	2.8	3.2	3.9	90	14110	287	269	281

\*Sectoral Shape for conductor size > 25 mm<sup>2</sup>

\*\*Overall Diameter Tolerance Range: [-2%, +6%]



## Multicore (5 Cores) - Aluminium Conductor, PVC Insulated Armored Cables

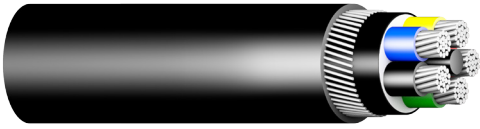

Conductor : Round Stranded Aluminium  
 Insulation : Extruded PVC Material  
 Armor : Galvanized Steel Wires  
 Oversheath : Extruded Material (PVC or PE)

5-Cores AL/PVC/SWA/Sheathed 600/1000 V Cables as per IEC 60502-1								Continuous Current Rating		
Nominal Area	Number of Strands	Approx Conductor Diameter	Nominal Insulation Thickness	Nominal Armor wire Diameter	Nominal Outer Sheath Thickness	Approx. Overall Diameter*	Approx. Cable Weight	Ground	Duct [Gd]	Free Air
								Amps	Amps	Amps
mm	No.	mm	mm	mm	mm	mm	kg/km			
5 x 10	7	3.9	1.0	1.6	1.8	25	1260	37	31	28
5 x 16	7	4.7	1.0	1.6	1.8	27	1480	48	41	37
5 x 25	7	6.3	1.2	1.6	1.9	33	2050	62	54	51
5 x 35	7	7.4	1.2	2.0	2.0	37	2550	74	65	62
5 x 50	19	8.8	1.4	2.0	2.2	43	3200	88	78	76
5 x 70	19	10.6	1.4	2.0	2.3	48	3920	107	96	95
5 x 95	19	12.4	1.6	2.5	2.5	56	5450	128	116	117
5 x 120	37	14	1.6	2.5	2.7	61	6280	145	132	136
5 x 150	37	15.5	1.8	2.5	2.9	66	7370	161	147	153
5 x 185	37	17.4	2.0	2.5	3.0	73	8690	182	168	176
5 x 240	61	19.9	2.2	3.2	3.3	83	11510	207	193	206
5 x 300	61	22.2	2.4	3.2	3.6	91	13670	230	215	232
5 x 400	61	25.2	2.6	3.2	3.9	101	16400	257	242	266
5 x 500	61	28.6	2.8	3.2	4.2	112	19780	284	271	301

\*Overall Diameter Tolerance Range: [-2% , +6%]

## Multicore (2 & 3 Cores) - Copper Conductor, XLPE Insulated Armored Cables

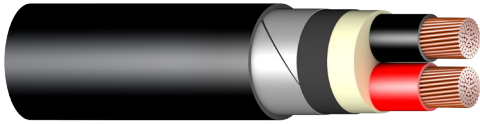

Conductor : Round Stranded Copper  
 Insulation : Extruded XLPE Material  
 Armor : Galvanized Steel Tapes  
 Oversheath : Extruded Material (PVC, LSF or PE)

2-Cores CU/XLPE/STA/Sheathed 600/1000 V Cables as per IEC 60502-1								Continuous Current Rating		
Nominal Area	Number of Strands	Approx Conductor Diameter	Nominal Insulation Thickness	Nominal Armor Tape Thickness	Nominal Outer Sheath Thickness	Approx. Overall Diameter*	Approx. Cable Weight	Ground	Duct [Gd]	Free Air
								Amps	Amps	Amps
mm	No.	mm	mm	mm	mm	mm	kg/km			
2 x 1.5	7	1.6	0.7	0.2	1.8	13	260	25	21	21
2 x 2.5	7	2.0	0.7	0.2	1.8	14	310	32	27	28
2 x 4	7	2.6	0.7	0.2	1.8	15	370	42	35	37
2 x 6	7	3.1	0.7	0.2	1.8	16	440	53	44	47
2 x 10	7	4.0	0.7	0.2	1.8	18	570	70	59	64
2 x 16	7	5.0	0.7	0.2	1.8	20	760	91	76	84
2 x 25	7	6.3	0.9	0.2	1.8	24	1060	117	99	113
2 x 35	7	7.4	0.9	0.2	1.8	26	1340	140	120	138
2 x 50	19	8.8	1.0	0.2	1.8	29	1710	166	143	168
2 x 70	19	10.6	1.1	0.2	1.9	33	2310	203	176	212
2 x 95	19	12.4	1.1	0.2	2.0	37	3050	242	211	259
2 x 120	37	14.0	1.2	0.5	2.1	42	4130	276	244	303
2 x 150	37	15.5	1.4	0.5	2.3	47	4970	309	275	346
2 x 185	37	17.4	1.6	0.5	2.4	52	6130	348	312	396
2 x 240	61	20.3	1.7	0.5	2.6	58	7800	401	364	467
2 x 300	61	22.7	1.8	0.5	2.7	64	9560	449	411	533
2 x 400	61	25.4	2.0	0.5	3.0	71	11930	504	464	608
2 x 500	61	28.8	2.2	0.5	3.2	79	14940	562	520	691

\*Overall Diameter Tolerance Range: [-2% , +6%]

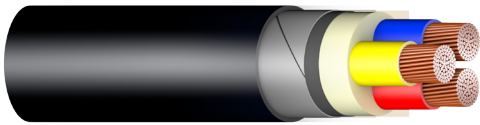

Conductor : Round Stranded Copper  
 Insulation : Extruded XLPE Material  
 Armor : Galvanized Steel Tapes  
 Oversheath : Extruded Material (PVC, LSF or PE)

3-Cores CU/XLPE/STA/Sheathed 600/1000 V Cables as per IEC 60502-1								Continuous Current Rating		
Nominal Area	Number of Strands	Approx Conductor Diameter	Nominal Insulation Thickness	Nominal Armor Tape Thickness	Nominal Outer Sheath Thickness	Approx. Overall Diameter*	Approx. Cable Weight	Ground	Duct [Gd]	Free Air
								Amps	Amps	Amps
mm	No.	mm	mm	mm	mm	mm	kg/km			
3 x 1.5	7	1.6	0.7	0.2	1.8	14	280	21	18	18
3 x 2.5	7	2.0	0.7	0.2	1.8	15	340	27	23	24
3 x 4	7	2.6	0.7	0.2	1.8	16	410	36	30	32
3 x 6	7	3.1	0.7	0.2	1.8	17	500	44	37	40
3 x 10	7	4.0	0.7	0.2	1.8	19	680	59	50	55
3 x 16	7	5.0	0.7	0.2	1.8	21	910	76	64	72
3 x 25	7	6.3	0.9	0.2	1.8	25	1300	98	83	97
3 x 35	7	7.4	0.9	0.2	1.8	27	1540	115	99	115
3 x 50	19	8.8	1.0	0.2	1.8	31	1970	137	118	141
3 x 70	19	10.6	1.1	0.2	1.9	36	2720	167	146	177
3 x 95	19	12.4	1.1	0.2	2.1	40	3600	199	175	217
3 x 120	37	14.0	1.2	0.5	2.2	45	4840	227	202	253
3 x 150	37	15.5	1.4	0.5	2.4	50	5890	254	227	287
3 x 185	37	17.4	1.6	0.5	2.5	55	7200	285	258	329
3 x 240	61	20.3	1.7	0.5	2.7	63	9250	329	299	388
3 x 300	61	22.7	1.8	0.5	2.9	69	11340	367	337	441
3 x 400	61	25.4	2.0	0.5	3.1	76	14190	411	381	501
3 x 500	61	28.8	2.2	0.5	3.3	85	17900	456	425	567

\*Overall Diameter Tolerance Range: [-2% , +6%]



## Multicore (3½ & 4 Cores) - Copper Conductor, XLPE Insulated Armored Cables



Conductor : Round / Sectoral Strande Copper  
 Insulation : Extruded XLPE Material  
 Armor : Galvanized Steel Tapes  
 Oversheath : Extruded Material (PVC, LSF or PE)

3½ Cores CU/XLPE/STA/Sheathed 600/1000 V Cables as per IEC 60502-1								Continuous Current Rating		
Nominal Area*	Number of Strands	Approx Conductor Diameter	Nominal Insulation Thickness	Nominal Armor Tape Thickness	Nominal Outer Sheath Thickness	Approx. Overall Diameter**	Approx. Cable Weight	Ground	Duct [Gd]	Free Air
								Amps	Amps	Amps
mm	No.	mm	mm	mm	mm	mm	kg/km			
3x16+10	7 / 7	5 / 4	0.7 / 0.7	0.2	1.8	22	1030	76	64	73
3x25+16	7 / 7	6.3 / 5	0.9 / 0.7	0.2	1.8	26	1470	99	84	98
3x35+16	7 / 7	6.6 / 5	0.9 / 0.7	0.2	1.8	26	1620	114	98	113
3x50+25	19 / 7	7.5 / 6.3	1.0 / 0.9	0.2	1.8	29	2120	135	117	137
3x70+35	19 / 7	9.1 / 7.4	1.1 / 0.9	0.2	2.0	34	2960	165	144	173
3x95+50	19 / 19	11 / 8.8	1.1 / 1.0	0.5	2.1	39	4230	198	175	214
3x120+70	37 / 19	12.2 / 10.6	1.2 / 1.1	0.5	2.3	43	5260	225	199	247
3x150+70	37 / 19	13.8 / 10.6	1.4 / 1.1	0.5	2.4	47	6290	251	224	280
3x185+95	37 / 19	15.1 / 12.4	1.6 / 1.1	0.5	2.6	52	7790	283	254	320
3x240+120	61 / 37	17.6 / 14	1.7 / 1.2	0.5	2.8	58	9930	325	295	375
3x300+150	61 / 37	19.8 / 15.5	1.8 / 1.4	0.5	2.9	63	12120	364	331	427
3x400+185	61 / 37	22.2 / 17.4	2.0 / 1.6	0.5	3.2	71	15250	409	377	491
3x500+240	61 / 61	26.3 / 20.3	2.2 / 1.7	0.5	3.4	78	19240	456	422	555

\*Sectoral Shape for conductor size > 25 mm<sup>2</sup>

\*\*Overall Diameter Tolerance Range: [-2% , +6%]

[Ph]: Phase [Ne]: Neutral



Conductor : Round / Sectoral Stranded Copper  
 Insulation : Extruded XLPE Material  
 Armor : Galvanized Steel Tapes  
 Oversheath : Extruded Material (PVC, LSF or PE)

4-Cores CU/XLPE/STA/Sheathed 600/1000 V Cables as per IEC 60502-1								Continuous Current Rating		
Nominal Area*	Number of Strands	Approx Conductor Diameter	Nominal Insulation Thickness	Nominal Armor Tape Thickness	Nominal Outer Sheath Thickness	Approx. Overall Diameter**	Approx. Cable Weight	Ground	Duct [Gd]	Free Air
								Amps	Amps	Amps
mm	No.	mm	mm	mm	mm	mm	kg/km			
4 x 1.5	7	1.6	0.7	0.2	1.8	15	320	21	18	19
4 x 2.5	7	2.0	0.7	0.2	1.8	16	390	28	23	25
4 x 4	7	2.6	0.7	0.2	1.8	17	480	36	30	32
4 x 6	7	3.1	0.7	0.2	1.8	18	590	45	37	41
4 x 10	7	4.0	0.7	0.2	1.8	20	810	59	50	56
4 x 16	7	5.0	0.7	0.2	1.8	23	1110	77	65	75
4 x 25	7	6.3	0.9	0.2	1.8	27	1600	99	84	100
4 x 35	7	6.6	0.9	0.2	1.8	27	1810	115	98	115
4 x 50	19	7.5	1.0	0.2	1.9	31	2340	136	117	140
4 x 70	19	9.1	1.1	0.2	2.0	35	3270	166	145	175
4 x 95	19	11.0	1.1	0.5	2.2	40	4700	199	175	216
4 x 120	37	12.2	1.2	0.5	2.4	45	5810	226	201	249
4 x 150	37	13.8	1.4	0.5	2.5	49	7060	253	226	284
4 x 185	37	15.1	1.6	0.5	2.7	54	8660	284	257	324
4 x 240	61	17.6	1.7	0.5	2.9	60	11110	327	296	380
4 x 300	61	19.8	1.8	0.5	3.1	66	13630	366	335	433
4 x 400	61	22.2	2.0	0.5	3.4	75	17280	412	381	496
4 x 500	61	26.3	2.2	0.8	3.7	84	22470	461	430	566



\*Sectoral Shape for conductor size > 25 mm<sup>2</sup>

\*\*Overall Diameter Tolerance Range: [-2% , +6%]

## Multicore (5 Cores) - Copper Conductor, XLPE Insulated Armored Cables



Conductor : Round Stranded Copper  
 Insulation : Extruded XLPE Material  
 Armor : Galvanized Steel Tapes  
 Oversheath : Extruded Material (PVC, LSF or PE)

5-Cores CU/XLPE/STA/Sheathed 600/1000 V Cables as per IEC 60502-1								Continuous Current Rating		
Nominal Area	Number of Strands	Approx Conductor Diameter	Nominal Insulation Thickness	Nominal Armor Tape Thickness	Nominal Outer Sheath Thickness	Approx. Overall Diameter*	Approx. Cable Weight	Ground	Duct [Gd]	Free Air
								Amps	Amps	Amps
mm	No.	mm	mm	mm	mm	mm	kg/km			
5 x 1.5	7	1.6	0.7	0.2	1.8	15	360	21	18	19
5 x 2.5	7	2.0	0.7	0.2	1.8	17	440	28	24	25
5 x 4	7	2.6	0.7	0.2	1.8	18	560	36	30	33
5 x 6	7	3.1	0.7	0.2	1.8	20	690	45	38	42
5 x 10	7	4.0	0.7	0.2	1.8	22	960	60	51	58
5 x 16	7	5.0	0.7	0.2	1.8	25	1330	78	66	77
5 x 25	7	6.3	0.9	0.2	1.8	29	1940	100	86	103
5 x 35	7	7.4	0.9	0.2	1.9	33	2380	120	104	127
5 x 50	19	8.8	1.0	0.2	2.0	37	3140	142	124	154
5 x 70	19	10.6	1.1	0.5	2.2	44	4720	175	154	196
5 x 95	19	12.4	1.1	0.5	2.3	50	6250	209	186	241
5 x 120	37	14.0	1.2	0.5	2.5	55	7700	237	213	279
5 x 150	37	15.5	1.4	0.5	2.7	61	9310	265	241	319
5 x 185	37	17.4	1.6	0.5	2.9	68	11560	299	273	365
5 x 240	61	20.3	1.7	0.5	3.1	76	14810	345	319	431
5 x 300	61	22.7	1.8	0.5	3.3	84	18310	385	358	491
5 x 400	61	25.4	2.0	0.8	3.7	95	23970	433	407	562
5 x 500	61	28.8	2.2	0.8	4.0	105	30110	482	457	637

\*Overall Diameter Tolerance Range: [-2% , +6%]



## Multicore (2 & 3 Cores) - Aluminium Conductor, XLPE Insulated Armored Cables

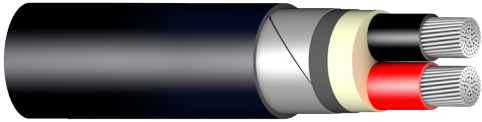

Conductor : Round Stranded Aluminium  
 Insulation : Extruded XLPE Material  
 Armor : Galvanized Steel Tapes  
 Oversheath : Extruded Material (PVC, LSF or PE)

2-Cores AL/XLPE/STA/Sheathed 600/1000 V Cables as per IEC 60502-1								Continuous Current Rating		
Nominal Area	Number of Strands	Approx Conductor Diameter	Nominal Insulation Thickness	Nominal Armor Tape Thickness	Nominal Outer Sheath Thickness	Approx. Overall Diameter*	Approx. Cable Weight	Ground	Duct [Gd]	Free Air
								Amps	Amps	Amps
mm	No.	mm	mm	mm	mm	mm	kg/km			
2 x 10	7	3.9	0.7	0.2	1.8	18	430	54	45	49
2 x 16	7	4.7	0.7	0.2	1.8	19	520	69	59	64
2 x 25	7	6.3	0.9	0.2	1.8	23	740	90	77	87
2 x 35	7	7.4	0.9	0.2	1.8	25	890	108	92	106
2 x 50	19	8.8	1.0	0.2	1.8	28	1110	128	109	129
2 x 70	19	10.6	1.1	0.2	1.9	33	1470	158	137	164
2 x 95	19	12.4	1.1	0.2	2.0	37	1880	188	164	201
2 x 120	37	14	1.2	0.5	2.1	42	2650	215	190	236
2 x 150	37	15.5	1.4	0.5	2.3	46	3150	240	214	268
2 x 185	37	17.4	1.6	0.5	2.4	51	3850	272	244	308
2 x 240	61	19.9	1.7	0.5	2.6	57	4750	315	286	366
2 x 300	61	22.2	1.8	0.5	2.7	63	5710	355	323	420
2 x 400	61	25.2	2.0	0.5	3.0	70	7060	405	373	487
2 x 500	61	28.6	2.2	0.5	3.2	78	8670	462	428	566

\*Overall Diameter Tolerance Range: [-2% , +6%]

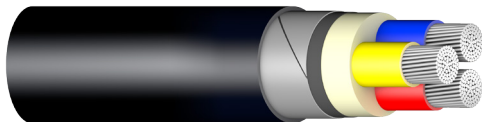

Conductor : Round Stranded Aluminium  
 Insulation : Extruded XLPE Material  
 Armor : Galvanized Steel Tapes  
 Oversheath : Extruded Material (PVC, LSF or PE)

3-Cores AL/XLPE/STA/Sheathed 600/1000 V Cables as per IEC 60502-1								Continuous Current Rating		
Nominal Area	Number of Strands	Approx Conductor Diameter	Nominal Insulation Thickness	Nominal Armor Tape Thickness	Nominal Outer Sheath Thickness	Approx. Overall Diameter*	Approx. Cable Weight	Ground	Duct [Gd]	Free Air
								Amps	Amps	Amps
mm	No.	mm	mm	mm	mm	mm	kg/km			
3 x 10	7	3.9	0.7	0.2	1.8	18	470	45	37	41
3 x 16	7	4.7	0.7	0.2	1.8	20	580	58	49	55
3 x 25	7	6.3	0.9	0.2	1.8	24	830	76	64	74
3 x 35	7	7.4	0.9	0.2	1.8	27	900	89	76	89
3 x 50	19	8.8	1.0	0.2	1.8	31	1110	106	91	109
3 x 70	19	10.6	1.1	0.2	1.9	36	1490	130	114	138
3 x 95	19	12.4	1.1	0.2	2.1	40	1890	155	136	169
3 x 120	37	14	1.2	0.5	2.2	45	2680	177	158	197
3 x 150	37	15.5	1.4	0.5	2.4	50	3220	198	177	224
3 x 185	37	17.4	1.6	0.5	2.5	55	3860	224	202	258
3 x 240	61	19.9	1.7	0.5	2.7	62	4800	260	236	305
3 x 300	61	22.2	1.8	0.5	2.9	68	5710	292	268	350
3 x 400	61	25.2	2.0	0.5	3.1	75	7010	333	308	405
3 x 500	61	28.6	2.2	0.5	3.3	85	8630	379	353	470

\*Overall Diameter Tolerance Range: [-2% , +6%]

## Multicore (3½ & 4 Cores) - Aluminium Conductor, XLPE Insulated Armored Cables

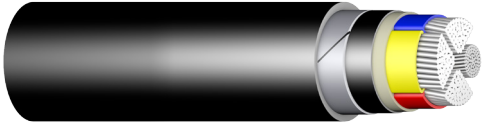

Conductor : Round / Sectoral Stranded Aluminium  
 Insulation : Extruded XLPE Material  
 Armor : Galvanized Steel Tapes  
 Oversheath : Extruded Material (PVC, LSF or PE)

3½ Cores AL/XLPE/STA/Sheathed 600/1000 V Cables as per IEC 60502-1								Continuous Current Rating		
Nominal Area*	Number of Strands	Approx Conductor Diameter	Nominal Insulation Thickness	Nominal Armor Tape Thickness	Nominal Outer Sheath Thickness	Approx. Overall Diameter**	Approx. Cable Weight	Ground	Duct [Gd]	Free Air
								Amps	Amps	Amps
mm	No.	mm	mm	mm	mm	mm	kg/km			
3x16+10	7 / 7	4.7 / 3.9	0.7 / 0.7	0.2	1.8	21	650	59	49	56
3x25+16	7 / 7	6.3 / 4.7	0.9 / 0.7	0.2	1.8	25	900	76	64	76
3x35+16	7 / 7	6.5 / 4.7	0.9 / 0.7	0.2	1.8	26	890	89	76	88
3x50+25	7 / 7	7.5 / 6.3	1.0 / 0.9	0.2	1.8	29	1120	105	91	107
3x70+35	14 / 7	9.1 / 7.4	1.1 / 0.9	0.2	2.0	34	1490	128	112	134
3x95+50	19 / 19	10.8 / 8.8	1.1 / 1.0	0.5	2.1	39	2210	154	136	166
3x120+70	19 / 19	12.2 / 10.6	1.2 / 1.1	0.5	2.3	43	2660	175	155	192
3x150+70	37 / 19	13.5 / 10.6	1.4 / 1.1	0.5	2.4	47	3160	196	174	218
3x185+95	37 / 19	15.2 / 12.4	1.6 / 1.1	0.5	2.6	52	3820	222	199	251
3x240+120	37 / 37	17.5 / 14	1.7 / 1.2	0.5	2.8	58	4740	256	233	296
3x300+150	37 / 37	19.6 / 15.5	1.8 / 1.4	0.5	2.9	63	5620	289	263	339
3x400+185	61 / 37	22.5 / 17.4	2.0 / 1.6	0.5	3.2	71	6980	330	304	396
3x500+240	61 / 61	25.6 / 19.9	2.2 / 1.7	0.5	3.4	78	8610	375	347	455

\*Sectoral Shape for conductor size > 25 mm<sup>2</sup>

\*\*Overall Diameter Tolerance Range: [-2%, +6%]

[Ph]: Phase [Ne]: Neutral

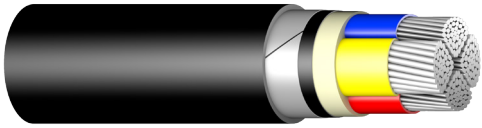

Conductor : Round / Sectoral Stranded Aluminium  
 Insulation : Extruded XLPE Material  
 Armor : Galvanized Steel Tapes  
 Oversheath : Extruded Material (PVC, LSF or PE)

4-Cores AL/XLPE/STA/Sheathed 600/1000 V Cables as per IEC 60502-1								Continuous Current Rating		
Nominal Area*	Number of Strands	Approx Conductor Diameter	Nominal Insulation Thickness	Nominal Armor Tape Thickness	Nominal Outer Sheath Thickness	Approx. Overall Diameter**	Approx. Cable Weight	Ground	Duct [Gd]	Free Air
								Amps	Amps	Amps
mm	No.	mm	mm	mm	mm	mm	kg/km			
4 x 10	7	3.9	0.7	0.2	1.8	20	550	46	38	43
4 x 16	7	4.7	0.7	0.2	1.8	22	680	59	50	57
4 x 25	7	6.3	0.9	0.2	1.8	26	990	77	65	77
4 x 35	7	6.5	0.9	0.2	1.8	27	960	89	76	89
4 x 50	7	7.5	1.0	0.2	1.9	31	1200	106	91	109
4 x 70	14	9.1	1.1	0.2	2.0	35	1590	129	113	136
4 x 95	19	10.8	1.1	0.5	2.2	40	2390	155	136	167
4 x 120	19	12.2	1.2	0.5	2.4	45	2890	176	157	194
4 x 150	37	13.5	1.4	0.5	2.5	49	3440	197	176	221
4 x 185	37	15.2	1.6	0.5	2.7	54	4130	223	201	254
4 x 240	37	17.5	1.7	0.5	2.9	60	5160	258	234	299
4 x 300	37	19.6	1.8	0.5	3.1	66	6150	291	266	343
4 x 400	61	22.5	2.0	0.5	3.4	75	7740	332	307	400
4 x 500	61	25.6	2.2	0.8	3.7	84	10230	379	353	464

\*Sectoral Shape for conductor size > 25 mm<sup>2</sup>

\*\*Overall Diameter Tolerance Range: [-2%, +6%]



## Multicore (5 Cores) - Aluminium Conductor, XLPE Insulated Armored Cables

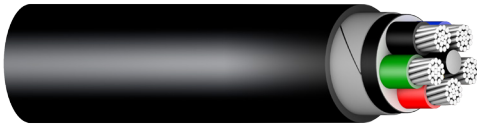

Conductor : Round Stranded Aluminium  
 Insulation : Extruded XLPE Material  
 Armor : Galvanized Steel Tapes  
 Oversheath : Extruded Material (PVC, LSF or PE)

5-Cores AL/XLPE/STA/Sheathed 600/1000 V Cables as per IEC 60502-1								Continuous Current Rating		
Nominal Area	Number of Strands	Approx Conductor Diameter	Nominal Insulation Thickness	Nominal Armor Tape Thickness	Nominal Outer Sheath Thickness	Approx. Overall Diameter*	Approx. Cable Weight	Ground	Duct [Gd]	Free Air
								Amps	Amps	Amps
mm	No.	mm	mm	mm	mm	mm	kg/km			
5 x 10	7	3.9	0.7	0.2	1.8	21	640	46	39	44
5 x 16	7	4.7	0.7	0.2	1.8	23	810	60	50	58
5 x 25	7	6.3	0.9	0.2	1.8	29	1180	78	67	80
5 x 35	7	7.4	0.9	0.2	1.9	32	1330	93	80	98
5 x 50	19	8.8	1.0	0.2	2.0	37	1720	110	96	119
5 x 70	19	10.6	1.1	0.5	2.2	44	2690	136	120	152
5 x 95	19	12.4	1.1	0.5	2.3	50	3400	162	145	188
5 x 120	37	14	1.2	0.5	2.5	55	4090	185	166	218
5 x 150	37	15.5	1.4	0.5	2.7	61	4870	207	188	249
5 x 185	37	17.4	1.6	0.5	2.9	68	5990	235	215	286
5 x 240	61	19.9	1.7	0.5	3.1	75	7400	272	250	339
5 x 300	61	22.2	1.8	0.5	3.3	83	8950	307	285	389
5 x 400	61	25.2	2.0	0.8	3.7	94	11990	351	329	455
5 x 500	61	28.6	2.2	0.8	4.0	105	14650	400	379	528

\*Overall Diameter Tolerance Range: [-2% , +6%]

## Multicore (2 & 3 Cores) - Copper Conductor, PVC Insulated Armored Cables



Conductor : Round Stranded Copper  
 Insulation : Extruded PVC Material  
 Armor : Galvanized Steel Tapes  
 Oversheath : Extruded Material (PVC or PE)

2-Cores CU/PVC/STA/Sheathed 600/1000 V Cables as per IEC 60502-1								Continuous Current Rating		
Nominal Area	Number of Strands	Approx Conductor Diameter	Nominal Insulation Thickness	Nominal Armor Tape Thickness	Nominal Outer Sheath Thickness	Approx. Overall Diameter*	Approx. Cable Weight	Ground	Duct [Gd]	Free Air
								Amps	Amps	Amps
mm	No.	mm	mm	mm	mm	mm	kg/km			
2 x 1.5	7	1.6	0.8	0.2	1.8	14	280	19	17	13
2 x 2.5	7	2.0	0.8	0.2	1.8	15	330	25	22	17
2 x 4	7	2.6	1.0	0.2	1.8	16	430	33	28	23
2 x 6	7	3.1	1.0	0.2	1.8	18	500	41	35	29
2 x 10	7	4.0	1.0	0.2	1.8	19	650	55	47	39
2 x 16	7	5.0	1.0	0.2	1.8	21	840	71	60	52
2 x 25	7	6.3	1.2	0.2	1.8	25	1170	91	78	70
2 x 35	7	7.4	1.2	0.2	1.8	27	1460	110	95	85
2 x 50	19	8.8	1.4	0.2	1.8	31	1870	130	113	104
2 x 70	19	10.6	1.4	0.2	1.9	34	2470	159	139	130
2 x 95	19	12.4	1.6	0.2	2.1	40	3330	190	168	160
2 x 120	37	14.0	1.6	0.5	2.2	44	4410	217	193	187
2 x 150	37	15.5	1.8	0.5	2.3	48	5270	242	218	212
2 x 185	37	17.4	2.0	0.5	2.4	53	6480	272	246	242
2 x 240	61	20.3	2.2	0.5	2.6	60	8270	314	286	287
2 x 300	61	22.7	2.4	0.5	2.8	67	10190	352	324	326
2 x 400	61	25.4	2.6	0.5	3.1	74	12650	394	365	372
2 x 500	61	28.8	2.8	0.5	3.3	82	15860	438	408	421

\*Overall Diameter Tolerance Range: [-2% , +6%]

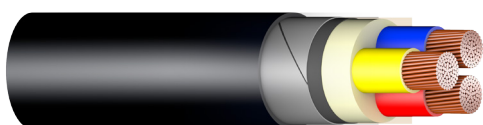

Conductor : Round Stranded Copper  
 Insulation : Extruded PVC Material  
 Armor : Galvanized Steel Tapes  
 Oversheath : Extruded Material (PVC or PE)

3-Cores CU/PVC/STA/Sheathed 600/1000 V Cables as per IEC 60502-1								Continuous Current Rating		
Nominal Area	Number of Strands	Approx Conductor Diameter	Nominal Insulation Thickness	Nominal Armor Tape Thickness	Nominal Outer Sheath Thickness	Approx. Overall Diameter*	Approx. Cable Weight	Ground	Duct [Gd]	Free Air
								Amps	Amps	Amps
mm	No.	mm	mm	mm	mm	mm	kg/km			
3 x 1.5	7	1.6	0.8	0.2	1.8	14	310	17	14	11
3 x 2.5	7	2.0	0.8	0.2	1.8	15	370	22	18	15
3 x 4	7	2.6	1.0	0.2	1.8	17	480	28	24	20
3 x 6	7	3.1	1.0	0.2	1.8	18	580	35	29	25
3 x 10	7	4.0	1.0	0.2	1.8	20	760	46	39	34
3 x 16	7	5.0	1.0	0.2	1.8	23	1010	60	51	45
3 x 25	7	6.3	1.2	0.2	1.8	26	1430	77	66	60
3 x 35	7	7.4	1.2	0.2	1.8	29	1660	91	79	72
3 x 50	19	8.8	1.4	0.2	1.9	33	2160	108	94	88
3 x 70	19	10.6	1.4	0.2	2.0	37	2910	132	116	110
3 x 95	19	12.4	1.6	0.5	2.2	43	4290	158	140	136
3 x 120	37	14.0	1.6	0.5	2.3	47	5150	180	160	157
3 x 150	37	15.5	1.8	0.5	2.4	52	6230	201	181	179
3 x 185	37	17.4	2.0	0.5	2.6	57	7640	225	205	204
3 x 240	61	20.3	2.2	0.5	2.8	65	9810	259	238	241
3 x 300	61	22.7	2.4	0.5	2.9	71	12000	290	267	273
3 x 400	61	25.4	2.6	0.5	3.2	79	15000	324	300	311
3 x 500	61	28.8	2.8	0.5	3.4	88	18850	359	336	351

\*Overall Diameter Tolerance Range: [-2% , +6%]



## Multicore (3½ & 4 Cores) - Copper Conductor, PVC Insulated Armored Cables

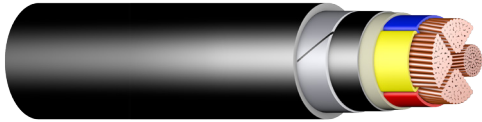

Conductor : Round / Sectoral Stranded Copper  
 Insulation : Extruded PVC Material  
 Armor : Galvanized Steel Tapes  
 Oversheath : Extruded Material (PVC or PE)

3½ Cores CU/PVC/STA/Sheathed 600/1000 V Cables as per IEC 60502-1								Continuous Current Rating		
Nominal Area*	Number of Strands	Approx Conductor Diameter	Nominal Insulation Thickness	Nominal Armor Tape Thickness	Nominal Outer Sheath Thickness	Approx. Overall Diameter**	Approx. Cable Weight	Ground	Duct [Gd]	Free Air
								Amps	Amps	Amps
mm	No.	mm	mm	mm	mm	mm	kg/km			
3x16+10	7 / 7	5 / 4	1.0 / 1.0	0.2	1.8	24	1150	61	52	46
3x25+16	7 / 7	6.3 / 5	1.2 / 1.0	0.2	1.8	27	1620	78	67	61
3x35+16	7 / 7	6.6 / 5	1.2 / 1.0	0.2	1.8	28	1760	91	78	71
3x50+25	19 / 7	7.5 / 6.3	1.4 / 1.2	0.2	1.9	32	2340	107	94	86
3x70+35	19 / 7	9.1 / 7.4	1.4 / 1.2	0.2	2.0	35	3160	130	115	107
3x95+50	19 / 19	11 / 8.8	1.6 / 1.4	0.5	2.2	41	4590	157	138	133
3x120+70	37 / 19	12.2 / 10.6	1.6 / 1.4	0.5	2.3	45	5640	178	159	153
3x150+70	37 / 19	13.8 / 10.6	1.8 / 1.4	0.5	2.5	49	6690	198	178	174
3x185+95	37 / 19	15.1 / 12.4	2.0 / 1.6	0.5	2.6	54	8240	223	202	199
3x240+120	61 / 37	17.6 / 14	2.2 / 1.6	0.5	2.8	60	10500	256	233	233
3x300+150	61 / 37	19.8 / 15.5	2.4 / 1.8	0.5	3.0	66	12860	287	263	266
3x400+185	61 / 37	22.2 / 17.4	2.6 / 2.0	0.5	3.3	74	16210	322	298	303
3x500+240	61 / 61	26.3 / 20.3	2.8 / 2.2	0.8	3.6	83	21070	359	336	346

\*Sectoral Shape for conductor size > 25 mm<sup>2</sup>

\*\*Overall Diameter Tolerance Range: [-2% , +6%]

[Ph]: Phase [Ne]: Neutral



Conductor : Round / Sectoral Stranded Copper  
 Insulation : Extruded PVC Material  
 Armor : Galvanized Steel Tapes  
 Oversheath : Extruded Material (PVC or PE)

4-Cores CU/PVC/STA/Sheathed 600/1000 V Cables as per IEC 60502-1								Continuous Current Rating		
Nominal Area*	Number of Strands	Approx Conductor Diameter	Nominal Insulation Thickness	Nominal Armor Tape Thickness	Nominal Outer Sheath Thickness	Approx. Overall Diameter**	Approx. Cable Weight	Ground	Duct [Gd]	Free Air
								Amps	Amps	Amps
mm	No.	mm	mm	mm	mm	mm	kg/km			
4 x 1.5	7	1.6	0.8	0.2	1.8	15	350	17	14	12
4 x 2.5	7	2.0	0.8	0.2	1.8	16	420	22	18	15
4 x 4	7	2.6	1.0	0.2	1.8	18	570	28	24	20
4 x 6	7	3.1	1.0	0.2	1.8	20	690	35	30	26
4 x 10	7	4.0	1.0	0.2	1.8	22	920	47	40	35
4 x 16	7	5.0	1.0	0.2	1.8	24	1230	61	52	46
4 x 25	7	6.3	1.2	0.2	1.8	28	1760	78	67	62
4 x 35	7	6.6	1.2	0.2	1.8	29	1960	91	79	72
4 x 50	19	7.5	1.4	0.2	2.0	33	2600	107	94	87
4 x 70	19	9.1	1.4	0.5	2.1	38	3840	132	116	110
4 x 95	19	11.0	1.6	0.5	2.3	43	5080	157	140	135
4 x 120	37	12.2	1.6	0.5	2.4	47	6160	178	159	155
4 x 150	37	13.8	1.8	0.5	2.6	52	7500	200	180	177
4 x 185	37	15.1	2.0	0.5	2.7	57	9200	224	204	202
4 x 240	61	17.6	2.2	0.5	3.0	63	11760	258	236	236
4 x 300	61	19.8	2.4	0.5	3.2	69	14440	288	265	269
4 x 400	61	22.2	2.6	0.5	3.5	78	18240	324	301	308
4 x 500	61	26.3	2.8	0.8	3.8	87	23610	362	339	351

\*Sectoral Shape for conductor size > 25 mm<sup>2</sup>

\*\*Overall Diameter Tolerance Range: [-2% , +6%]

## Multicore (3½ & 4 Cores) - Copper Conductor, PVC Insulated Armored Cables

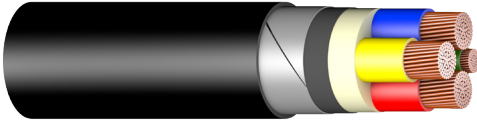

Conductor : Round Stranded Copper  
 Insulation : Extruded PVC Material  
 Fillers : Extruded Bourage Material  
 Armor : Galvanized Steel Tapes  
 Oversheath : Extruded PVC Material

3½ Cores CU/PVC/STA/Sheathed 600/1000 V Cables as per IEC 60502-1 and MOE Iraq Specification D-04								Continuous Current Rating		
Nominal Area*	Number of Strands [Ph/Ne]	Approx Conductor Diameter [Ph/Ne]	Nominal Insulation Thickness [Ph/Ne]	Nominal Armor Tape Thickness	Nominal Outer Sheath Thickness	Approx. Overall Diameter**	Approx. Cable Weight	Ground	Duct [Gd]	Free Air
								Amps	Amps	Amps
mm	No.	mm	mm	mm	mm	mm	kg/km			
3x50+25	19 / 7	8.8 / 6.3	1.4 / 1.2	0.2	1.9	32	2550	107	94	86
3x70+35	19 / 7	10.6 / 7.4	1.4 / 1.2	0.2	2.0	36	3420	130	115	107
3x95+50	19 / 19	12.4 / 8.8	1.6 / 1.4	0.5	2.2	43	4960	157	138	133
3x120+70	37 / 19	14.0 / 10.6	1.6 / 1.4	0.5	2.3	47	6160	178	159	153
3x150+95	37 / 19	15.5 / 12.4	1.8 / 1.6	0.5	2.5	52	7590	198	178	174
3x185+95	37 / 19	17.4 / 12.4	2.0 / 1.6	0.5	2.6	56	8940	223	202	199
3x240+120	61 / 37	20.3 / 14	2.2 / 1.6	0.5	2.8	63	11400	256	233	233
3x300+150	61 / 37	22.7 / 15.5	2.4 / 1.8	0.5	3.0	69	13940	287	263	266

\*\*Overall Diameter Tolerance Range: [-2% , +6%]

[Ph]: Phase [Ne]: Neutral

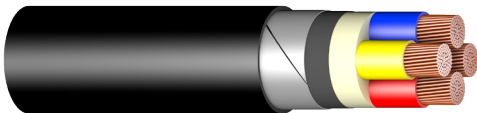

Conductor : Round Stranded Copper  
 Insulation : Extruded PVC Material  
 Fillers : Extruded Bourage Material  
 Armor : Galvanized Steel Tapes  
 Oversheath : Extruded PVC Material

4-Cores CU/PVC/STA/Sheathed 600/1000 V Cables as per IEC 60502-1 and MOE Iraq Specification D-04								Continuous Current Rating		
Nominal Area*	Number of Strands	Approx Conductor Diameter	Nominal Insulation Thickness	Nominal Armor Tape Thickness	Nominal Outer Sheath Thickness	Approx. Overall Diameter**	Approx. Cable Weight	Ground	Duct [Gd]	Free Air
								Amps	Amps	Amps
mm	No.	mm	mm	mm	mm	mm	kg/km			
4 x 1.5	7	1.6	0.8	0.2	1.8	15	350	17	14	12
4 x 2.5	7	2.0	0.8	0.2	1.8	16	420	22	18	15
4 x 4	7	2.6	1.0	0.2	1.8	18	570	28	24	20
4 x 6	7	3.1	1.0	0.2	1.8	20	690	35	30	26
4 x 10	7	4.0	1.0	0.2	1.8	22	920	47	40	35
4 x 16	7	5.0	1.0	0.2	1.8	24	1200	61	52	46
4 x 25	7	6.3	1.2	0.2	1.8	28	1710	78	67	62
4 x 35	7	7.4	1.2	0.2	1.8	30	2165	91	79	72
4 x 50	19	8.8	1.4	0.2	2.0	35	2900	107	94	87
4 x 70	19	10.6	1.4	0.5	2.1	40	4220	132	116	110
4 x 95	19	12.4	1.6	0.5	2.3	45	5590	157	140	135
4 x 120	37	14.0	1.6	0.5	2.4	49	6830	178	159	155
4 x 150	37	15.5	1.8	0.5	2.6	54	8275	200	180	177
4 x 185	37	17.4	2.0	0.5	2.7	60	10170	224	204	202
4 x 240	61	20.3	2.2	0.5	3.0	67	13050	258	236	236

\*\*Overall Diameter Tolerance Range: [-2% , +6%]



## Multicore (5 Cores) - Copper Conductor, PVC Insulated Armored Cables



Conductor : Round Stranded Copper  
 Insulation : Extruded PVC Material  
 Armor : Galvanized Steel Tapes  
 Oversheath : Extruded Material (PVC or PE)

5-Cores CU/PVC/STA/Sheathed 600/1000 V Cables as per IEC 60502-1								Continuous Current Rating		
Nominal Area	Number of Strands	Approx Conductor Diameter	Nominal Insulation Thickness	Nominal Armor Tape Thickness	Nominal Outer Sheath Thickness	Approx. Overall Diameter*	Approx. Cable Weight	Ground	Duct [Gd]	Free Air
								Amps	Amps	Amps
mm	No.	mm	mm	mm	mm	mm	kg/km			
5 x 1.5	7	1.6	0.8	0.2	1.8	16	400	17	14	12
5 x 2.5	7	2.0	0.8	0.2	1.8	17	490	22	19	16
5 x 4	7	2.6	1.0	0.2	1.8	20	660	29	24	21
5 x 6	7	3.1	1.0	0.2	1.8	21	810	36	30	26
5 x 10	7	4.0	1.0	0.2	1.8	24	1090	48	41	36
5 x 16	7	5.0	1.0	0.2	1.8	26	1480	61	53	48
5 x 25	7	6.3	1.2	0.2	1.8	31	2140	79	68	64
5 x 35	7	7.4	1.2	0.2	1.9	34	2590	95	82	78
5 x 50	19	8.8	1.4	0.2	2.1	40	3450	112	99	96
5 x 70	19	10.6	1.4	0.5	2.2	46	5040	138	123	122
5 x 95	19	12.4	1.6	0.5	2.4	53	6760	165	148	149
5 x 120	37	14.0	1.6	0.5	2.6	57	8200	187	170	172
5 x 150	37	15.5	1.8	0.5	2.8	63	9970	209	190	196
5 x 185	37	17.4	2.0	0.5	2.9	70	12230	236	217	225
5 x 240	61	20.3	2.2	0.5	3.2	79	15720	272	252	266
5 x 300	61	22.7	2.4	0.5	3.4	88	19450	304	284	303
5 x 400	61	25.4	2.6	0.8	3.8	98	25320	341	321	346
5 x 500	61	28.8	2.8	0.8	4.1	109	31820	379	360	391

\*Overall Diameter Tolerance Range: [-2% , +6%]

## Multicore (2 & 3 Cores) - Aluminium Conductor, PVC Insulated Armored Cables

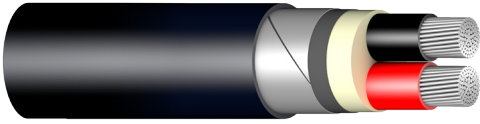

Conductor : Round Stranded Aluminium  
 Insulation : Extruded PVC Material  
 Armor : Galvanized Steel Tapes  
 Oversheath : Extruded Material (PVC or PE)

2-Cores AL/PVC/STA/Sheathed 600/1000 V Cables as per IEC 60502-1								Continuous Current Rating		
Nominal Area	Number of Strands	Approx Conductor Diameter	Nominal Insulation Thickness	Nominal Armor Tape Thickness	Nominal Outer Sheath Thickness	Approx. Overall Diameter*	Approx. Cable Weight	Ground	Duct [Gd]	Free Air
								Amps	Amps	Amps
mm	No.	mm	mm	mm	mm	mm	kg/km			
2 x 10	7	3.9	1.0	0.2	1.8	19	500	42	36	30
2 x 16	7	4.7	1.0	0.2	1.8	20	600	54	46	40
2 x 25	7	6.3	1.2	0.2	1.8	24	840	71	61	54
2 x 35	7	7.4	1.2	0.2	1.8	27	1010	85	73	66
2 x 50	19	8.8	1.4	0.2	1.8	30	1280	101	87	80
2 x 70	19	10.6	1.4	0.2	1.9	34	1620	124	108	101
2 x 95	19	12.4	1.6	0.2	2.1	39	2160	148	131	124
2 x 120	37	14	1.6	0.5	2.2	44	2930	169	150	146
2 x 150	37	15.5	1.8	0.5	2.3	48	3450	189	170	165
2 x 185	37	17.4	2.0	0.5	2.4	53	4210	214	193	190
2 x 240	61	19.9	2.2	0.5	2.6	59	5210	248	225	225
2 x 300	61	22.2	2.4	0.5	2.8	65	6320	279	256	257
2 x 400	61	25.2	2.6	0.5	3.1	73	7780	318	295	299
2 x 500	61	28.6	2.8	0.5	3.3	81	9570	362	337	346

\*Overall Diameter Tolerance Range: [-2% , +6%]

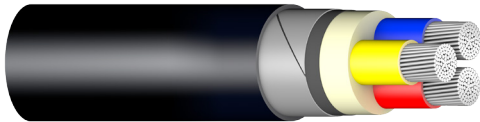

Conductor : Round Stranded Aluminium  
 Insulation : Extruded PVC Material  
 Armor : Galvanized Steel Tapes  
 Oversheath : Extruded Material (PVC or PE)

3-Cores AL/PVC/STA/Sheathed 600/1000 V Cables as per IEC 60502-1								Continuous Current Rating		
Nominal Area	Number of Strands	Approx Conductor Diameter	Nominal Insulation Thickness	Nominal Armor Tape Thickness	Nominal Outer Sheath Thickness	Approx. Overall Diameter*	Approx. Cable Weight	Ground	Duct [Gd]	Free Air
								Amps	Amps	Amps
mm	No.	mm	mm	mm	mm	mm	kg/km			
3 x 10	7	3.9	1.0	0.2	1.8	20	560	36	30	26
3 x 16	7	4.7	1.0	0.2	1.8	21	680	46	39	34
3 x 25	7	6.3	1.2	0.2	1.8	26	960	60	52	47
3 x 35	7	7.4	1.2	0.2	1.8	29	1030	71	61	56
3 x 50	19	8.8	1.4	0.2	1.9	33	1300	84	73	68
3 x 70	19	10.6	1.4	0.2	2.0	37	1690	103	90	86
3 x 95	19	12.4	1.6	0.5	2.2	43	2580	123	109	106
3 x 120	37	14	1.6	0.5	2.3	47	2990	140	125	123
3 x 150	37	15.5	1.8	0.5	2.4	52	3570	157	141	140
3 x 185	37	17.4	2.0	0.5	2.6	57	4290	177	161	161
3 x 240	61	19.9	2.2	0.5	2.8	64	5350	205	188	190
3 x 300	61	22.2	2.4	0.5	2.9	70	6370	231	213	217
3 x 400	61	25.2	2.6	0.5	3.2	78	7810	263	244	252
3 x 500	61	28.6	2.8	0.5	3.4	87	9570	299	280	291

\*Overall Diameter Tolerance Range: [-2% , +6%]



## Multicore (3½ & 4 Cores) - Aluminium Conductor, PVC Insulated Armored Cables

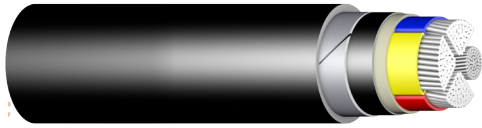

Conductor : Round / Sectoral Stranded Aluminium  
 Insulation : Extruded PVC Material  
 Armor : Galvanized Steel Tapes  
 Oversheath : Extruded Material (PVC or PE)

3½ Cores AL/PVC/STA/Sheathed 600/1000 V Cables as per IEC 60502-1								Continuous Current Rating		
Nominal Area*	Number of Strands	Approx Conductor Diameter [Ph/Ne]	Nominal Insulation Thickness [Ph/Ne]	Nominal Armor Tape Thickness	Nominal Outer Sheath Thickness	Approx. Overall Diameter**	Approx. Cable Weight	Ground	Duct [Gd]	Free Air
								Amps	Amps	Amps
mm	No.	mm	mm	mm	mm	mm	kg/km			
3x16+10	7 / 7	4.7 / 3.9	1.0 / 1.0	0.2	1.8	23	760	47	40	35
3x25+16	7 / 7	6.3 / 4.7	1.2 / 1.0	0.2	1.8	27	1050	60	52	47
3x35+16	7 / 7	6.5 / 4.7	1.2 / 1.0	0.2	1.8	28	1030	70	60	55
3x50+25	7 / 7	7.5 / 6.3	1.4 / 1.2	0.2	1.9	32	1330	83	73	67
3x70+35	14 / 7	9.1 / 7.4	1.4 / 1.2	0.2	2.0	35	1690	102	89	83
3x95+50	19 / 19	10.8 / 8.8	1.6 / 1.4	0.5	2.2	41	2560	122	108	103
3x120+70	19 / 19	12.2 / 10.6	1.6 / 1.4	0.5	2.3	45	3040	139	124	120
3x150+70	37 / 19	13.5 / 10.6	1.8 / 1.4	0.5	2.5	49	3560	155	139	136
3x185+95	37 / 19	15.2 / 12.4	2.0 / 1.6	0.5	2.6	54	4270	175	159	157
3x240+120	37 / 37	17.5 / 14	2.2 / 1.6	0.5	2.8	60	5320	203	184	184
3x300+150	37 / 37	19.6 / 15.5	2.4 / 1.8	0.5	3.0	66	6360	228	209	211
3x400+185	61 / 37	22.5 / 17.4	2.6 / 2.0	0.5	3.3	74	7940	260	241	245
3x500+240	61 / 61	25.6 / 19.9	2.8 / 2.2	0.8	3.6	83	10420	296	277	285

\*Sectoral Shape for conductor size > 25 mm<sup>2</sup>

\*\*Overall Diameter Tolerance Range: [-2% , +6%]

[Ph]: Phase [Ne]: Neutral

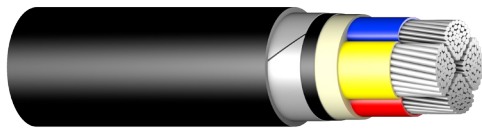

Conductor : Round / Sectoral Stranded Aluminium  
 Insulation : Extruded PVC Material  
 Armor : Galvanized Steel Tapes  
 Oversheath : Extruded Material (PVC or PE)

4-Cores AL/PVC/STA/Sheathed 600/1000 V Cables as per IEC 60502-1								Continuous Current Rating		
Nominal Area*	Number of Strands	Approx Conductor Diameter [Ph/Ne]	Nominal Insulation Thickness [Ph/Ne]	Nominal Armor Tape Thickness	Nominal Outer Sheath Thickness	Approx. Overall Diameter**	Approx. Cable Weight	Ground	Duct [Gd]	Free Air
								Amps	Amps	Amps
mm	No.	mm	mm	mm	mm	mm	kg/km			
4 x 10	7	3.9	1.0	0.2	1.8	21	650	36	30	27
4 x 16	7	4.7	1.0	0.2	1.8	23	800	47	40	35
4 x 25	7	6.3	1.2	0.2	1.8	28	1150	61	52	48
4 x 35	7	6.5	1.2	0.2	1.8	29	1110	71	61	56
4 x 50	7	7.5	1.4	0.2	2.0	33	1470	83	73	67
4 x 70	14	9.1	1.4	0.5	2.1	38	2160	102	91	86
4 x 95	19	10.8	1.6	0.5	2.3	43	2760	122	109	105
4 x 120	19	12.2	1.6	0.5	2.4	47	3240	139	124	121
4 x 150	37	13.5	1.8	0.5	2.6	52	3870	156	141	138
4 x 185	37	15.2	2.0	0.5	2.7	57	4670	176	160	158
4 x 240	37	17.5	2.2	0.5	3.0	63	5810	204	186	187
4 x 300	37	19.6	2.4	0.5	3.2	69	6960	230	211	214
4 x 400	61	22.5	2.6	0.5	3.5	78	8700	262	244	249
4 x 500	61	25.6	2.8	0.8	3.8	87	11370	298	280	289



\*Sectoral Shape for conductor size > 25 mm<sup>2</sup>

\*\*Overall Diameter Tolerance Range: [-2% , +6%]

## Multicore (5 Cores) - Aluminium Conductor, PVC Insulated Armored Cables



Conductor : Round Stranded Aluminium  
 Insulation : Extruded PVC Material  
 Armor : Galvanized Steel Tapes  
 Oversheath : Extruded Material (PVC or PE)

5-Cores AL/PVC/STA/Sheathed 600/1000 V Cables as per IEC 60502-1								Continuous Current Rating		
Nominal Area	Number of Strands	Approx Conductor Diameter	Nominal Insulation Thickness	Nominal Armor Tape Thickness	Nominal Outer Sheath Thickness	Approx. Overall Diameter*	Approx. Cable Weight	Ground	Duct [Gd]	Free Air
								Amps	Amps	Amps
mm	No.	mm	mm	mm	mm	mm	kg/km			
5 x 10	7	3.9	1.0	0.2	1.8	23	770	36	31	28
5 x 16	7	4.7	1.0	0.2	1.8	25	950	47	40	36
5 x 25	7	6.3	1.2	0.2	1.8	30	1370	61	53	49
5 x 35	7	7.4	1.2	0.2	1.9	34	1540	74	64	61
5 x 50	19	8.8	1.4	0.2	2.1	40	2020	87	77	74
5 x 70	19	10.6	1.4	0.5	2.2	46	3000	107	96	95
5 x 95	19	12.4	1.6	0.5	2.4	53	3910	128	115	116
5 x 120	37	14	1.6	0.5	2.6	57	4600	146	133	135
5 x 150	37	15.5	1.8	0.5	2.8	63	5530	163	149	153
5 x 185	37	17.4	2.0	0.5	2.9	70	6650	185	171	177
5 x 240	61	19.9	2.2	0.5	3.2	78	8290	215	199	210
5 x 300	61	22.2	2.4	0.5	3.4	86	10060	242	227	240
5 x 400	61	25.2	2.6	0.8	3.8	97	13340	277	261	280
5 x 500	61	28.6	2.8	0.8	4.1	109	16340	315	300	325

\*Overall Diameter Tolerance Range: [-2% , +6%]



## Single Core - Copper Conductor, XLPE Insulated Cables [90°C]

Electrical Parameters [TOUCHED Cables in Trefoil & Flat Formation ]											
Nominal Area	DC Resistance [20 °C]	DC Resistance [90 °C]	AC Resistance [90 °C]	Inductance	Reactance [60 Hz]	Impedance [90 °C]	Voltage Drop 3-φ	Voltage Drop 1-φ	Capacitance	Min. Insulation Resistance [20°C]	Short Circuit Current [Conductor]
mm	Ω/km	Ω/km	Ω/km	mH/km	Ω/km	Ω/km	V/A/km	V/A/km	μF/km	MΩ.km	kA
1 x 1.5	12.10	15.43	15.43	0.597	0.225	15.43	21.61	24.96	0.103	1045	0.21
1 x 2.5	7.41	9.45	9.45	0.546	0.206	9.45	13.31	15.37	0.114	840	0.36
1 x 4	4.61	5.88	5.88	0.514	0.194	5.88	8.35	9.64	0.121	720	0.57
1 x 6	3.08	3.93	3.93	0.474	0.179	3.93	5.63	6.50	0.131	585	0.86
1 x 10	1.83	2.33	2.33	0.439	0.165	2.34	3.41	3.93	0.140	475	1.43
1 x 16	1.15	1.47	1.47	0.407	0.153	1.48	2.19	2.53	0.149	385	2.29
1 x 25	0.727	0.927	0.927	0.387	0.146	0.939	1.44	1.66	0.147	400	3.58
1 x 35	0.524	0.668	0.668	0.365	0.138	0.683	1.07	1.24	0.153	340	5.01
1 x 50	0.387	0.494	0.494	0.353	0.133	0.511	0.823	0.950	0.155	330	7.15
1 x 70	0.268	0.342	0.342	0.336	0.127	0.365	0.606	0.700	0.157	310	10.02
1 x 95	0.193	0.246	0.247	0.321	0.121	0.275	0.468	0.541	0.162	260	13.59
1 x 120	0.153	0.195	0.197	0.305	0.115	0.228	0.392	0.452	0.163	255	17.17
1 x 150	0.124	0.158	0.160	0.307	0.116	0.198	0.342	0.395	0.161	270	21.46
1 x 185	0.0991	0.126	0.129	0.298	0.112	0.171	0.295	0.340	0.161	275	26.47
1 x 240	0.0754	0.0961	0.0992	0.292	0.110	0.148	0.252	0.291	0.163	255	34.34
1 x 300	0.0601	0.0766	0.0807	0.281	0.106	0.133	0.222	0.256	0.165	240	42.93
1 x 400	0.0470	0.0599	0.0650	0.280	0.105	0.123	0.199	0.230	0.165	235	57.23
1 x 500	0.0366	0.0467	0.0529	0.278	0.105	0.118	0.182	0.211	0.166	230	71.54
1 x 630	0.0283	0.0361	0.0436	0.276	0.104	0.113	0.168	0.195	0.166	235	90.14
1 x 800	0.0221	0.0282	0.0368	0.275	0.104	0.110	0.159	0.184	0.166	230	114.47

Electrical Parameters [SPACED Cables in Trefoil & Flat Formation ]											
Nominal Area	DC Resistance [20 °C]	DC Resistance [90 °C]	AC Resistance [90 °C]	Inductance	Reactance [60 Hz]	Impedance [90 °C]	Voltage Drop 3-φ	Voltage Drop 1-φ	Capacitance	Min. Insulation Resistance [20°C]	Short Circuit Current [Conductor]
mm	Ω/km	Ω/km	Ω/km	mH/km	Ω/km	Ω/km	V/A/km	V/A/km	μF/km	MΩ.km	kA
1 x 1.5	12.10	15.43	15.43	0.782	0.295	15.43	21.69	24.96	0.103	1045	0.21
1 x 2.5	7.41	9.45	9.45	0.731	0.276	9.45	13.38	15.37	0.114	840	0.36
1 x 4	4.61	5.88	5.88	0.699	0.264	5.88	8.42	9.64	0.121	720	0.57
1 x 6	3.08	3.93	3.93	0.659	0.248	3.94	5.70	6.50	0.131	585	0.86
1 x 10	1.83	2.33	2.33	0.624	0.235	2.35	3.48	3.93	0.140	475	1.43
1 x 16	1.15	1.47	1.47	0.592	0.223	1.48	2.26	2.53	0.149	385	2.29
1 x 25	0.727	0.927	0.927	0.572	0.216	0.952	1.51	1.66	0.147	400	3.58
1 x 35	0.524	0.668	0.668	0.550	0.207	0.700	1.14	1.24	0.153	340	5.01
1 x 50	0.387	0.494	0.494	0.538	0.203	0.534	0.895	0.950	0.155	330	7.15
1 x 70	0.268	0.342	0.342	0.520	0.196	0.394	0.678	0.700	0.157	310	10.02
1 x 95	0.193	0.246	0.247	0.506	0.191	0.312	0.541	0.541	0.162	260	13.59
1 x 120	0.153	0.195	0.196	0.489	0.185	0.269	0.465	0.452	0.163	255	17.17
1 x 150	0.124	0.158	0.159	0.492	0.186	0.245	0.415	0.395	0.161	270	21.46
1 x 185	0.0991	0.126	0.128	0.483	0.182	0.222	0.367	0.340	0.161	275	26.47
1 x 240	0.0754	0.0961	0.0978	0.477	0.180	0.205	0.325	0.291	0.163	255	34.34
1 x 300	0.0601	0.0766	0.0788	0.466	0.176	0.193	0.295	0.256	0.165	240	42.93
1 x 400	0.0470	0.0599	0.0626	0.464	0.175	0.186	0.272	0.230	0.165	235	57.23
1 x 500	0.0366	0.0467	0.0500	0.463	0.174	0.181	0.254	0.211	0.166	230	71.54
1 x 630	0.0283	0.0361	0.0402	0.461	0.174	0.179	0.241	0.195	0.166	235	90.14
1 x 800	0.0221	0.0282	0.0331	0.460	0.173	0.176	0.231	0.184	0.166	230	114.47

## Single Core - Copper Conductor, PVC Insulated Cables [70°C]

Electrical Parameters [TOUCHED Cables in Trefoil & Flat Formation ]											
Nominal Area	DC Resistance [20 °C]	DC Resistance [70 °C]	AC Resistance [70 °C]	Inductance	Reactance [60 Hz]	Impedance [70 °C]	Voltage Drop 3-φ	Voltage Drop 1-φ	Capacitance	Min. Insulation Resistance [20°C]	Short Circuit Current [Conductor]
mm	Ω/km	Ω/km	Ω/km	mH/km	Ω/km	Ω/km	V/A/km	V/A/km	μF/km	MΩ.km	kA
1 x 1.5	12.10	14.48	14.48	0.597	0.225	14.48	20.30	23.43	0.315	15.0	0.17
1 x 2.5	7.41	8.87	8.87	0.546	0.206	8.87	12.50	14.43	0.348	10.0	0.29
1 x 4	4.61	5.52	5.52	0.514	0.194	5.52	7.85	9.06	0.346	10.0	0.46
1 x 6	3.08	3.69	3.69	0.489	0.184	3.69	5.30	6.17	0.375	10.0	0.69
1 x 10	1.83	2.19	2.19	0.452	0.171	2.20	3.21	3.71	0.405	10.0	1.15
1 x 16	1.15	1.38	1.38	0.420	0.158	1.39	2.07	2.39	0.434	10.0	1.84
1 x 25	0.727	0.870	0.870	0.387	0.146	0.882	1.36	1.57	0.437	5.1	2.88
1 x 35	0.524	0.627	0.627	0.376	0.142	0.643	1.02	1.17	0.459	5.0	4.03
1 x 50	0.387	0.463	0.463	0.353	0.133	0.482	0.780	0.901	0.458	5.0	5.75
1 x 70	0.268	0.321	0.321	0.336	0.127	0.346	0.577	0.667	0.477	5.0	8.05
1 x 95	0.193	0.231	0.232	0.329	0.124	0.263	0.450	0.52	0.482	5.0	10.93
1 x 120	0.153	0.183	0.186	0.312	0.118	0.219	0.378	0.437	0.494	5.0	13.8
1 x 150	0.124	0.148	0.150	0.307	0.116	0.190	0.329	0.38	0.492	5.0	17.25
1 x 185	0.0991	0.119	0.121	0.305	0.115	0.167	0.287	0.331	0.493	5.0	21.28
1 x 240	0.0754	0.0902	0.0934	0.298	0.112	0.146	0.246	0.284	0.498	5.0	27.6
1 x 300	0.0601	0.0719	0.0759	0.292	0.110	0.134	0.219	0.253	0.502	5.0	34.5
1 x 400	0.047	0.0562	0.0612	0.289	0.109	0.125	0.198	0.229	0.505	5.0	41.12
1 x 500	0.0366	0.0438	0.0501	0.282	0.106	0.117	0.180	0.207	0.510	5.0	51.4
1 x 630	0.0283	0.0339	0.0414	0.280	0.106	0.114	0.168	0.193	0.515	5.0	64.77
1 x 800	0.0221	0.0264	0.0353	0.275	0.104	0.110	0.157	0.181	0.525	5.0	82.24

Electrical Parameters [SPACED Cables in Trefoil & Flat Formation ]											
Nominal Area	DC Resistance [20 °C]	DC Resistance [70 °C]	AC Resistance [70 °C]	Inductance	Reactance [60 Hz]	Impedance [70 °C]	Voltage Drop 3-φ	Voltage Drop 1-φ	Capacitance	Min. Insulation Resistance [20°C]	Short Circuit Current [Conductor]
mm	Ω/km	Ω/km	Ω/km	mH/km	Ω/km	Ω/km	V/A/km	V/A/km	μF/km	MΩ.km	kA
1 x 1.5	12.10	14.48	14.48	0.782	0.295	14.48	20.37	23.43	0.315	15.0	0.17
1 x 2.5	7.41	8.87	8.87	0.731	0.276	8.87	12.57	14.43	0.348	10.0	0.29
1 x 4	4.61	5.52	5.52	0.699	0.264	5.52	7.92	9.06	0.346	10.0	0.46
1 x 6	3.08	3.69	3.69	0.674	0.254	3.69	5.37	6.17	0.375	10.0	0.69
1 x 10	1.83	2.19	2.19	0.637	0.240	2.20	3.28	3.71	0.405	10.0	1.15
1 x 16	1.15	1.38	1.38	0.605	0.228	1.40	2.14	2.39	0.434	10.0	1.84
1 x 25	0.727	0.870	0.870	0.572	0.216	0.900	1.43	1.57	0.437	5.1	2.88
1 x 35	0.524	0.627	0.627	0.561	0.211	0.662	1.09	1.17	0.459	5.0	4.03
1 x 50	0.387	0.463	0.463	0.538	0.203	0.506	0.853	0.901	0.458	5.0	5.75
1 x 70	0.268	0.321	0.321	0.520	0.196	0.376	0.649	0.667	0.477	5.0	8.05
1 x 95	0.193	0.231	0.232	0.514	0.194	0.302	0.523	0.52	0.482	5.0	10.93
1 x 120	0.153	0.183	0.184	0.497	0.187	0.262	0.450	0.437	0.494	5.0	13.8
1 x 150	0.124	0.148	0.149	0.492	0.186	0.239	0.401	0.38	0.492	5.0	17.25
1 x 185	0.0991	0.119	0.120	0.489	0.185	0.220	0.360	0.331	0.493	5.0	21.28
1 x 240	0.0754	0.0902	0.0920	0.483	0.182	0.204	0.319	0.284	0.498	5.0	27.6
1 x 300	0.0601	0.0719	0.0741	0.477	0.180	0.195	0.292	0.253	0.502	5.0	34.5
1 x 400	0.047	0.0562	0.0590	0.474	0.179	0.188	0.271	0.229	0.505	5.0	41.12
1 x 500	0.0366	0.0438	0.0473	0.467	0.176	0.182	0.252	0.207	0.510	5.0	51.4
1 x 630	0.0283	0.0339	0.0381	0.465	0.175	0.179	0.239	0.193	0.515	5.0	64.77
1 x 800	0.0221	0.0264	0.0316	0.460	0.173	0.176	0.229	0.181	0.525	5.0	82.24



## Multicore - Copper Conductor, XLPE Insulated Cables [90°C]

Electrical Parameters											
Nominal Area	DC Resistance [20 °C]	DC Resistance [90 °C]	AC Resistance [90 °C]	Inductance	Reactance [60 Hz]	Impedance [90 °C]	Voltage Drop 3-φ	Voltage Drop 1-φ	Capacitance	Min. Insulation Resistance [20°C]	Short Circuit Current [Conductor]
mm	Ω/km	Ω/km	Ω/km	mH/km	Ω/km	Ω/km	V/A/km	V/A/km	μF/km	MΩ.km	kA
1.5	12.10	15.43	15.43	0.319	0.120	15.43	21.50	24.83	0.103	1045	0.21
2.5	7.41	9.45	9.45	0.294	0.111	9.45	13.21	15.25	0.114	840	0.36
4	4.61	5.88	5.88	0.279	0.105	5.88	8.25	9.53	0.121	720	0.57
6	3.08	3.93	3.93	0.262	0.099	3.93	5.55	6.40	0.131	585	0.86
10	1.83	2.33	2.33	0.248	0.094	2.33	3.33	3.85	0.140	475	1.43
16	1.15	1.47	1.47	0.237	0.089	1.47	2.13	2.45	0.149	385	2.29
25	0.727	0.927	0.928	0.239	0.090	0.932	1.38	1.59	0.147	400	3.58
35	0.524	0.668	0.669	0.231	0.087	0.675	1.02	1.18	0.153	340	5.01
50	0.387	0.494	0.495	0.230	0.087	0.502	0.775	0.895	0.155	330	7.15
70	0.268	0.342	0.343	0.227	0.086	0.354	0.565	0.652	0.157	310	10.02
95	0.193	0.246	0.248	0.221	0.083	0.262	0.430	0.497	0.162	260	13.59
120	0.153	0.195	0.198	0.220	0.083	0.214	0.360	0.416	0.163	255	17.17
150	0.124	0.158	0.161	0.222	0.084	0.182	0.311	0.359	0.161	270	21.46
185	0.0991	0.126	0.130	0.223	0.084	0.155	0.268	0.309	0.161	275	26.47
240	0.0754	0.0961	0.101	0.220	0.083	0.131	0.227	0.262	0.163	255	34.34
300	0.0601	0.0766	0.0830	0.218	0.082	0.117	0.200	0.231	0.165	240	42.93
400	0.0470	0.0599	0.0678	0.218	0.082	0.106	0.179	0.207	0.165	235	57.23
500	0.0366	0.0467	0.0562	0.217	0.082	0.099	0.163	0.188	0.166	230	71.54

## Multicore - Copper Conductor, PVC Insulated Cables [70°C]

Electrical Parameters											
Nominal Area	DC Resistance [20 °C]	DC Resistance [70 °C]	AC Resistance [70 °C]	Inductance	Reactance [60 Hz]	Impedance [70 °C]	Voltage Drop 3-φ	Voltage Drop 1-φ	Capacitance	Min. Insulation Resistance [20°C]	Short Circuit Current [Conductor]
mm	Ω/km	Ω/km	Ω/km	mH/km	Ω/km	Ω/km	V/A/km	V/A/km	μF/km	MΩ.km	kA
1.5	12.10	14.48	14.4777	0.332	0.125	14.478	20.191	23.31	0.315	15.0	0.17
2.5	7.41	8.87	8.8661	0.305	0.115	8.867	12.405	14.32	0.348	10.0	0.29
4	4.61	5.52	5.5159	0.307	0.116	5.517	7.764	8.97	0.346	10.0	0.46
6	3.08	3.69	3.6853	0.287	0.108	3.687	5.219	6.03	0.375	10.0	0.69
10	1.83	2.19	2.1898	0.269	0.101	2.192	3.139	3.63	0.405	10.0	1.15
16	1.15	1.38	1.3763	0.255	0.096	1.38	2.007	2.32	0.434	10.0	1.84
25	0.727	0.870	0.8703	0.253	0.095	0.875	1.305	1.51	0.437	5.1	2.88
35	0.524	0.627	0.6276	0.244	0.092	0.634	0.965	1.12	0.459	5.0	4.03
50	0.387	0.463	0.464	0.244	0.092	0.473	0.739	0.853	0.458	5.0	5.75
70	0.268	0.321	0.3221	0.236	0.089	0.334	0.539	0.622	0.477	5.0	8.05
95	0.193	0.231	0.2329	0.235	0.088	0.249	0.414	0.478	0.482	5.0	10.93
120	0.153	0.183	0.1856	0.23	0.087	0.205	0.348	0.401	0.494	5.0	13.8
150	0.124	0.148	0.1515	0.231	0.087	0.175	0.3	0.347	0.492	5.0	17.25
185	0.0991	0.119	0.1225	0.23	0.087	0.15	0.26	0.300	0.493	5.0	21.28
240	0.0754	0.0902	0.0953	0.228	0.086	0.128	0.221	0.256	0.498	5.0	27.6
300	0.0601	0.0719	0.0782	0.227	0.086	0.116	0.198	0.228	0.502	5.0	34.5
400	0.047	0.0562	0.064	0.226	0.085	0.106	0.177	0.204	0.505	5.0	41.12
500	0.0366	0.0438	0.0532	0.224	0.085	0.1	0.162	0.187	0.510	5.0	51.4

## Single Core - Aluminium Conductor, XLPE Insulated Cables [90°C]

Electrical Parameters [TOUCHED Cables in Trefoil & Flat Formation ]											
Nominal Area	DC Resistance [20 °C]	DC Resistance [90 °C]	AC Resistance [90 °C]	Inductance	Reactance [60 Hz]	Impedance [90 °C]	Voltage Drop 3-φ	Voltage Drop 1-φ	Capacitance	Min. Insulation Resistance [20°C]	Short Circuit Current [Conductor]
mm	Ω/km	Ω/km	Ω/km	mH/km	Ω/km	Ω/km	V/A/km	V/A/km	μF/km	MΩ.km	kA
1 x 10	3.08	3.95	3.95	0.443	0.167	3.95	5.65	6.52	0.140	480	0.94
1 x 16	1.91	2.45	2.45	0.421	0.159	2.45	3.56	4.11	0.146	415	1.51
1 x 25	1.20	1.54	1.54	0.387	0.146	1.55	2.28	2.64	0.147	400	2.36
1 x 35	0.868	1.11	1.11	0.366	0.138	1.12	1.69	1.95	0.153	345	3.31
1 x 50	0.641	0.822	0.822	0.354	0.133	0.833	1.28	1.48	0.154	340	4.72
1 x 70	0.443	0.568	0.568	0.336	0.127	0.582	0.919	1.06	0.157	310	6.61
1 x 95	0.320	0.410	0.411	0.321	0.121	0.428	0.695	0.802	0.162	260	8.98
1 x 120	0.253	0.324	0.325	0.305	0.115	0.345	0.570	0.658	0.163	255	11.34
1 x 150	0.206	0.264	0.265	0.307	0.116	0.289	0.488	0.563	0.161	270	14.17
1 x 185	0.164	0.210	0.211	0.298	0.112	0.239	0.409	0.473	0.161	275	17.48
1 x 240	0.125	0.160	0.162	0.290	0.109	0.195	0.337	0.390	0.163	255	22.68
1 x 300	0.100	0.128	0.130	0.285	0.107	0.168	0.291	0.337	0.165	240	28.35
1 x 400	0.0778	0.100	0.102	0.281	0.106	0.147	0.252	0.291	0.165	235	37.79
1 x 500	0.0605	0.078	0.0808	0.279	0.105	0.132	0.221	0.255	0.166	230	47.24
1 x 630	0.0469	0.060	0.0644	0.270	0.102	0.121	0.195	0.225	0.167	225	59.52
1 x 800	0.0367	0.047	0.0523	0.269	0.102	0.115	0.178	0.0206	0.168	210	75.59

Electrical Parameters [SPACED Cables in Trefoil & Flat Formation ]											
Nominal Area	DC Resistance [20 °C]	DC Resistance [90 °C]	AC Resistance [90 °C]	Inductance	Reactance [60 Hz]	Impedance [90 °C]	Voltage Drop 3-φ	Voltage Drop 1-φ	Capacitance	Min. Insulation Resistance [20°C]	Short Circuit Current [Conductor]
mm	Ω/km	Ω/km	Ω/km	mH/km	Ω/km	Ω/km	V/A/km	V/A/km	μF/km	MΩ.km	kA
1 x 10	3.08	3.95	3.95	0.628	0.237	3.96	5.72	6.52	0.140	480	0.94
1 x 16	1.91	2.45	2.45	0.606	0.228	2.46	3.63	4.11	0.146	415	1.51
1 x 25	1.20	1.54	1.54	0.572	0.216	1.55	2.36	2.64	0.147	400	2.36
1 x 35	0.868	1.11	1.11	0.551	0.208	1.13	1.76	1.95	0.153	345	3.31
1 x 50	0.641	0.822	0.822	0.539	0.203	0.847	1.35	1.480	0.154	340	4.72
1 x 70	0.443	0.568	0.568	0.520	0.196	0.601	0.991	1.06	0.157	310	6.61
1 x 95	0.32	0.410	0.411	0.506	0.191	0.453	0.768	0.802	0.162	260	8.98
1 x 120	0.253	0.324	0.325	0.489	0.185	0.374	0.643	0.658	0.163	255	11.34
1 x 150	0.206	0.264	0.265	0.492	0.186	0.324	0.560	0.563	0.161	270	14.17
1 x 185	0.164	0.210	0.211	0.483	0.182	0.279	0.482	0.473	0.161	275	17.48
1 x 240	0.125	0.160	0.161	0.475	0.179	0.241	0.410	0.390	0.163	255	22.68
1 x 300	0.100	0.128	0.129	0.470	0.177	0.219	0.364	0.337	0.165	240	28.35
1 x 400	0.0778	0.100	0.101	0.466	0.176	0.203	0.325	0.291	0.165	235	37.79
1 x 500	0.0605	0.078	0.0795	0.464	0.175	0.192	0.294	0.255	0.166	230	47.24
1 x 630	0.0469	0.060	0.0626	0.455	0.172	0.183	0.268	0.225	0.167	225	59.52
1 x 800	0.0367	0.047	0.0502	0.454	0.171	0.178	0.250	0.0206	0.168	210	75.59



## Single Core - Aluminium Conductor, PVC Insulated Cables [70°C]

Electrical Parameters [TOUCHED Cables in Trefoil & Flat Formation]											
Nominal Area	DC Resistance [20 °C]	DC Resistance [70 °C]	AC Resistance [70 °C]	Inductance	Reactance [60 Hz]	Impedance [70 °C]	Voltage Drop 3-φ	Voltage Drop 1-φ	Capacitance	Min. Insulation Resistance [20°C]	Short Circuit Current [Conductor]
mm	Ω/km	Ω/km	Ω/km	mH/km	Ω/km	Ω/km	V/A/km	V/A/km	μF/km	MΩ.km	kA
1 x 10	3.08	3.70	3.70	0.457	0.172	3.71	5.31	6.13	0.404	6.5	0.76
1 x 16	1.91	2.30	2.30	0.421	0.159	2.30	3.35	3.86	0.424	5.6	1.22
1 x 25	1.20	1.44	1.44	0.387	0.146	1.45	2.15	2.48	0.437	5.1	1.90
1 x 35	0.868	1.04	1.04	0.377	0.142	1.05	1.59	1.84	0.457	4.4	2.66
1 x 50	0.641	0.770	0.770	0.354	0.133	0.782	1.210	1.39	0.456	4.5	3.80
1 x 70	0.443	0.532	0.533	0.336	0.127	0.548	0.870	1.01	0.477	3.8	5.32
1 x 95	0.320	0.384	0.385	0.329	0.124	0.404	0.662	0.765	0.482	3.7	7.22
1 x 120	0.253	0.304	0.305	0.312	0.118	0.327	0.545	0.629	0.494	3.3	9.12
1 x 150	0.206	0.248	0.248	0.307	0.116	0.274	0.465	0.537	0.492	3.4	11.40
1 x 185	0.164	0.197	0.198	0.305	0.115	0.229	0.394	0.455	0.493	3.3	14.07
1 x 240	0.125	0.150	0.152	0.296	0.112	0.189	0.327	0.377	0.497	3.2	18.25
1 x 300	0.100	0.120	0.122	0.296	0.112	0.166	0.286	0.330	0.501	3.1	22.81
1 x 400	0.0778	0.093	0.096	0.291	0.11	0.146	0.247	0.286	0.505	3.0	27.19
1 x 500	0.0605	0.073	0.076	0.284	0.107	0.131	0.217	0.250	0.510	2.8	33.99
1 x 630	0.0469	0.056	0.0607	0.274	0.103	0.120	0.191	0.221	0.521	2.5	42.83
1 x 800	0.0367	0.044	0.0496	0.269	0.102	0.113	0.175	0.202	0.533	2.2	54.39

Electrical Parameters [SPACED Cables in Trefoil & Flat Formation]											
Nominal Area	DC Resistance [20 °C]	DC Resistance [70 °C]	AC Resistance [70 °C]	Inductance	Reactance [60 Hz]	Impedance [70 °C]	Voltage Drop 3-φ	Voltage Drop 1-φ	Capacitance	Min. Insulation Resistance [20°C]	Short Circuit Current [Conductor]
mm	Ω/km	Ω/km	Ω/km	mH/km	Ω/km	Ω/km	V/A/km	V/A/km	μF/km	MΩ.km	kA
1 x 10	3.08	3.70	3.70	0.641	0.242	3.71	5.38	6.13	0.404	6.5	0.76
1 x 16	1.91	2.30	2.29	0.606	0.228	2.31	3.42	3.86	0.424	5.6	1.22
1 x 25	1.20	1.44	1.44	0.572	0.216	1.46	2.22	2.48	0.437	5.1	1.90
1 x 35	0.868	1.04	1.04	0.562	0.212	1.06	1.67	1.84	0.457	4.4	2.66
1 x 50	0.641	0.770	0.770	0.539	0.203	0.797	1.28	1.39	0.456	4.5	3.80
1 x 70	0.443	0.532	0.533	0.520	0.196	0.567	0.942	1.01	0.477	3.8	5.32
1 x 95	0.320	0.384	0.385	0.514	0.194	0.431	0.735	0.765	0.482	3.7	7.22
1 x 120	0.253	0.304	0.304	0.497	0.187	0.357	0.617	0.629	0.494	3.3	9.12
1 x 150	0.206	0.248	0.248	0.492	0.186	0.310	0.537	0.537	0.492	3.4	11.40
1 x 185	0.164	0.197	0.198	0.489	0.185	0.271	0.467	0.455	0.493	3.3	14.07
1 x 240	0.125	0.150	0.151	0.481	0.181	0.236	0.398	0.377	0.497	3.2	18.25
1 x 300	0.100	0.120	0.121	0.481	0.181	0.218	0.357	0.330	0.501	3.1	22.81
1 x 400	0.0778	0.093	0.0950	0.476	0.179	0.203	0.319	0.286	0.505	3.0	27.19
1 x 500	0.0605	0.073	0.0747	0.468	0.177	0.192	0.289	0.250	0.510	2.8	33.99
1 x 630	0.0469	0.056	0.0590	0.459	0.173	0.183	0.264	0.221	0.521	2.5	42.83
1 x 800	0.0367	0.044	0.0474	0.454	0.171	0.177	0.246	0.202	0.533	2.2	54.39

## Multicore - Aluminium Conductor, XLPE Insulated Cables [90°C]

Electrical Parameters											
Nominal Area	DC Resistance [20 °C]	DC Resistance [90 °C]	AC Resistance [90 °C]	Inductance	Reactance [60 Hz]	Impedance [90 °C]	Voltage Drop 3-φ	Voltage Drop 1-φ	Capacitance	Min. Insulation Resistance [20°C]	Short Circuit Current [Conductor]
mm	Ω/km	Ω/km	Ω/km	mH/km	Ω/km	Ω/km	V/A/km	V/A/km	μF/km	MΩ.km	kA
10	3.08	3.95	3.95	0.248	0.094	3.95	5.57	6.43	0.140	480	0.94
16	1.91	2.45	2.45	0.241	0.091	2.45	3.49	4.03	0.146	415	1.51
25	1.20	1.54	1.54	0.239	0.090	1.54	2.23	2.57	0.147	400	2.36
35	0.868	1.11	1.11	0.232	0.087	1.12	1.63	1.89	0.153	345	3.31
50	0.641	0.82	0.822	0.231	0.087	0.827	1.23	1.42	0.154	340	4.72
70	0.443	0.568	0.569	0.227	0.086	0.575	0.877	1.01	0.157	310	6.61
95	0.320	0.410	0.411	0.221	0.083	0.419	0.656	0.757	0.162	260	8.98
120	0.253	0.324	0.326	0.220	0.083	0.336	0.537	0.620	0.163	255	11.34
150	0.206	0.264	0.266	0.222	0.084	0.278	0.455	0.525	0.161	270	14.17
185	0.164	0.210	0.212	0.223	0.084	0.228	0.381	0.439	0.161	275	17.48
240	0.125	0.160	0.163	0.220	0.083	0.183	0.312	0.359	0.163	255	22.68
300	0.100	0.128	0.131	0.218	0.082	0.155	0.267	0.307	0.165	240	28.35
400	0.0778	0.100	0.103	0.218	0.082	0.132	0.228	0.263	0.165	235	37.79
500	0.0605	0.0780	0.0823	0.217	0.082	0.116	0.199	0.228	0.166	230	47.24

## Multicore - Aluminium Conductor, PVC Insulated Cables [70°C]

Electrical Parameters											
Nominal Area	DC Resistance [20 °C]	DC Resistance [70 °C]	AC Resistance [70 °C]	Inductance	Reactance [60 Hz]	Impedance [70 °C]	Voltage Drop 3-φ	Voltage Drop 1-φ	Capacitance	Min. Insulation Resistance [20°C]	Short Circuit Current [Conductor]
mm	Ω/km	Ω/km	Ω/km	mH/km	Ω/km	Ω/km	V/A/km	V/A/km	μF/km	MΩ.km	kA
10	3.08	3.70	3.70	0.270	0.102	3.70	5.23	6.04	0.404	6.5	0.76
16	1.91	2.30	2.30	0.260	0.098	2.30	3.28	3.79	0.424	5.6	1.22
25	1.20	1.440	1.44	0.253	0.095	1.45	2.10	2.42	0.437	5.1	1.90
35	0.868	1.04	1.04	0.245	0.092	1.05	1.54	1.78	0.457	4.4	2.66
50	0.641	0.770	0.770	0.245	0.092	0.776	1.16	1.34	0.456	4.5	3.80
70	0.443	0.532	0.533	0.236	0.089	0.540	0.831	0.959	0.477	3.8	5.32
95	0.320	0.384	0.385	0.235	0.088	0.395	0.625	0.722	0.482	3.7	7.22
120	0.253	0.304	0.305	0.230	0.087	0.317	0.513	0.592	0.494	3.3	9.12
150	0.206	0.248	0.249	0.231	0.087	0.264	0.435	0.502	0.492	3.4	11.40
185	0.164	0.197	0.199	0.230	0.087	0.217	0.366	0.422	0.493	3.3	14.07
240	0.125	0.150	0.153	0.229	0.086	0.175	0.301	0.346	0.497	3.2	18.25
300	0.100	0.120	0.123	0.228	0.086	0.150	0.260	0.299	0.501	3.1	22.81
400	0.0778	0.093	0.0972	0.226	0.085	0.129	0.223	0.256	0.505	3.0	27.19
500	0.0605	0.073	0.0774	0.224	0.085	0.115	0.196	0.224	0.510	2.8	33.99



## Typical Cables' Correction Factors for Variation in Installation Conditions In Ground

Correction Factors For Soil Thermal Resistivity				
T.R [°C.m/W]	Single-Core Cable	Multi-Core Cable	Single-Core (in Duct)	Multi-Core (in Duct)
1.00	1.36	1.29	1.25	1.17
1.20	1.26	1.21	1.18	1.12
1.50	1.14	1.12	1.10	1.07
2.00	1.00	1.00	1.00	1.00
2.50	0.90	0.91	0.91	0.93
3.00	0.80	0.80	0.80	0.80

Grouping Factors For Number of Circuits			
No. of Circuits	Trefoil [Gd]	Flat Spaced [Gd]	Multicore [Gd]
<b>1</b>	1.00	1.00	1.00
<b>2</b>			
125mm	0.80	0.78	0.82
250mm	0.84	0.83	0.86
500mm	0.89	0.88	0.89
<b>3</b>			
125mm	0.69	0.67	0.71
250mm	0.75	0.73	0.76
500mm	0.82	0.80	0.81
<b>4</b>			
125mm	0.63	0.61	0.65
250mm	0.70	0.68	0.72
500mm	0.78	0.77	0.77
<b>5</b>			
125mm	0.59	0.56	0.61
250mm	0.66	0.64	0.68
500mm	0.76	0.74	0.74
<b>6</b>			
125mm	0.56	0.54	0.58
250mm	0.64	0.62	0.66
500mm	0.74	0.73	0.72

Correction Factors For Ground Temperature	
Temp.[°C]	Factor
20	1.18
30	1.09
35	1.04
40	1.00
50	0.89
55	0.83

Correction Factors For Cable Depth	
Depth [mm]	Factor
500	1.02
700	1.00
1000	0.95
1200	0.94
1500	0.92
2000	0.85

## Typical Cables' Correction Factors for Variation in Installation Conditions In Air

<b>Grouping Factors</b>									
<b>Cables arrangement</b>	<b>No. of Circuits or Multi-Core Cables</b>								
	<b>1</b>	<b>2</b>	<b>3</b>	<b>4</b>	<b>5</b>	<b>6</b>	<b>7</b>	<b>8</b>	<b>9</b>
Bunched in air, on a surface, embedded or enclosed	1.00	0.80	0.70	0.65	0.60	0.57	0.54	0.52	0.50
Single layer on wall, floor or unperforated cable tray systems	1.00	0.85	0.79	0.75	0.73	0.72	0.72	0.71	0.70
Single layer fixed directly under a wooden ceiling	0.95	0.81	0.72	0.68	0.66	0.64	0.63	0.62	0.61
Single layer on a perforated horizontal or vertical cable tray systems	1.00	0.88	0.82	0.77	0.75	0.73	0.73	0.72	0.72
Single layer on cable ladder systems or cleats etc.,	1.00	0.87	0.82	0.80	0.80	0.79	0.79	0.78	0.78

<b>Correction Factors For Air Temperature</b>	
<b>Temp.[°C]</b>	<b>Factor</b>
<b>20</b>	1.49
<b>30</b>	1.36
<b>35</b>	1.29
<b>40</b>	1.22
<b>50</b>	1.08
<b>55</b>	1.00







# PRODUCTS PANORAMA

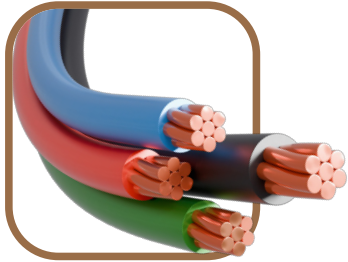

## **Wires** Up to 600 V

Used in the supply of electric power, lighting and internal wiring for residences and offices, and similar non- industrial.

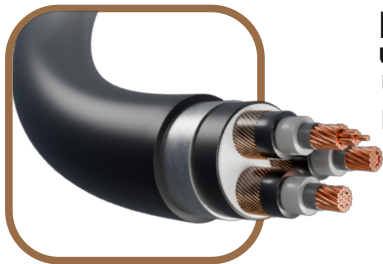

## **Low Voltage Cables** Up to 1000 V

Used to supply power to large motors and industrial equipment in both residential and industrial settings.

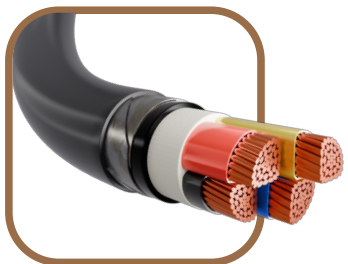

## **Medium Voltage Cables** Up to 36 kV

Distribution and transmission of power in infrastructure projects.

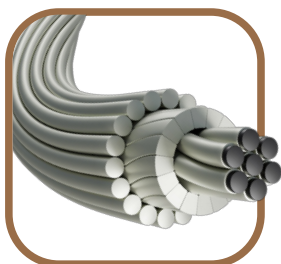

## **Overhead Lines**

Used for long distance power transmission and inter-city connections.

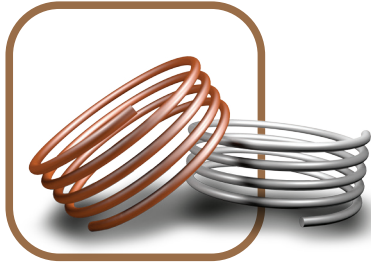

### **Copper Rods**

Al Rowad Cables manufactures 8 mm high-purity copper rods for cable conductors and metallic screens.

### **Aluminium Rods**

Al Rowad Cables produces 9.5 mm high-purity aluminum rods for power cable conductors, overhead lines, and armouring.



### **PVC Granules**

We produce high-quality PVC granules for cable insulation and sheathing, using advanced machinery and automatic mixing technology.

### **LV XLPE compounds**

We produce high-purity LV XLPE insulation material for low-voltage cables, utilizing advanced machinery and automatic mixing technology.



### **Wooden & Steel Drums**

Our facility is a state-of-the-art plant for manufacturing wooden and steel drums of various sizes for the cable industry, using high-speed production lines to ensure top quality at minimal cost.



## Drum Handling Instructions

Cables and conductors should be installed by trained personnel in accordance with good engineering practices, recognized codes of practice, statutory local requirements, IEE wiring regulations, and, where relevant, any specific instructions issued by the company. Cables are often supplied on heavy cable reels, and handling these reels can pose a safety hazard. In particular, dangers may arise during the removal of steel binding straps, as well as the removal of retaining battens and timbers, which may expose projecting nails.

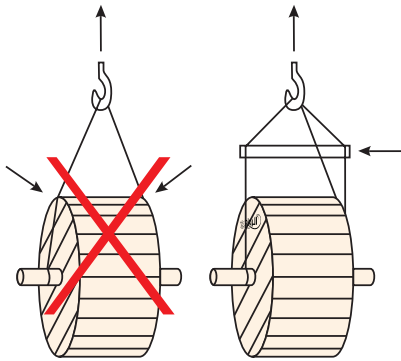

Lifting cable drums using crane.

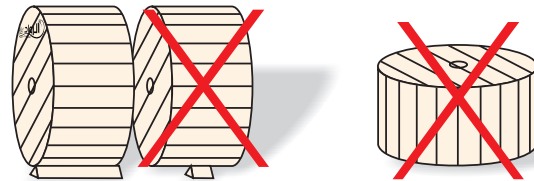

Do not lay drums flat on their sides, use proper stops to prevent drums rolling.

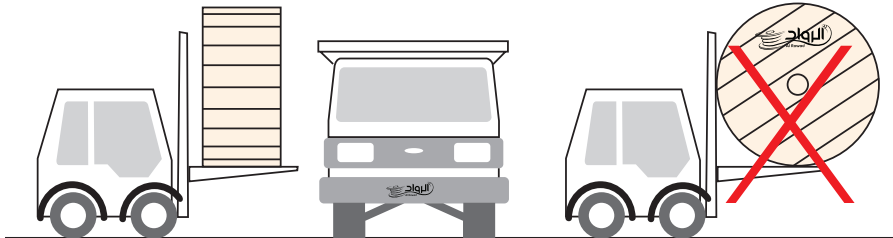

Lift drums on fork trucks correctly.

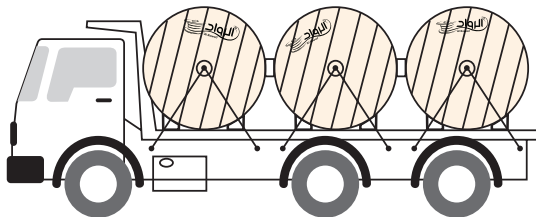

Secure drums adequately before transportation.

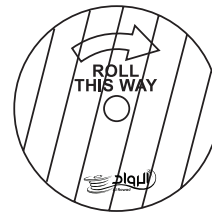

Roll in the direction shown by the arrow.

## Al Rowad Notice

The Al Rowad catalogues currently in circulation remain valid. However, some international and national standards referenced in the catalogues may be amended by their respective organizations without prior notice. For Al Rowad Cables products, the latest amendments to the applicable standards are adhered to.

For wires and wiring cables manufactured by Al Rowad Cables, the color codes specified in the respective standards are followed. Additionally, Al Rowad Cables can provide the following color codes as required by certain utilities:

- 1 Core: Red or Black. ● ●
- 2 Core: Red, Black. ● ●
- 3 Core: Red, Yellow, Blue. ● ● ●
- 4 Core: Red, Yellow, Blue, Black. ● ● ● ●
- 5 Core: Red, Yellow, Blue, Black, Green. ● ● ● ● ●

**More than 5 cores: Black cores with white printed numerals**

In the interest of continuous product improvement, **Al Rowad Cables** reserves the right to modify the information provided in this catalogue without prior notice.



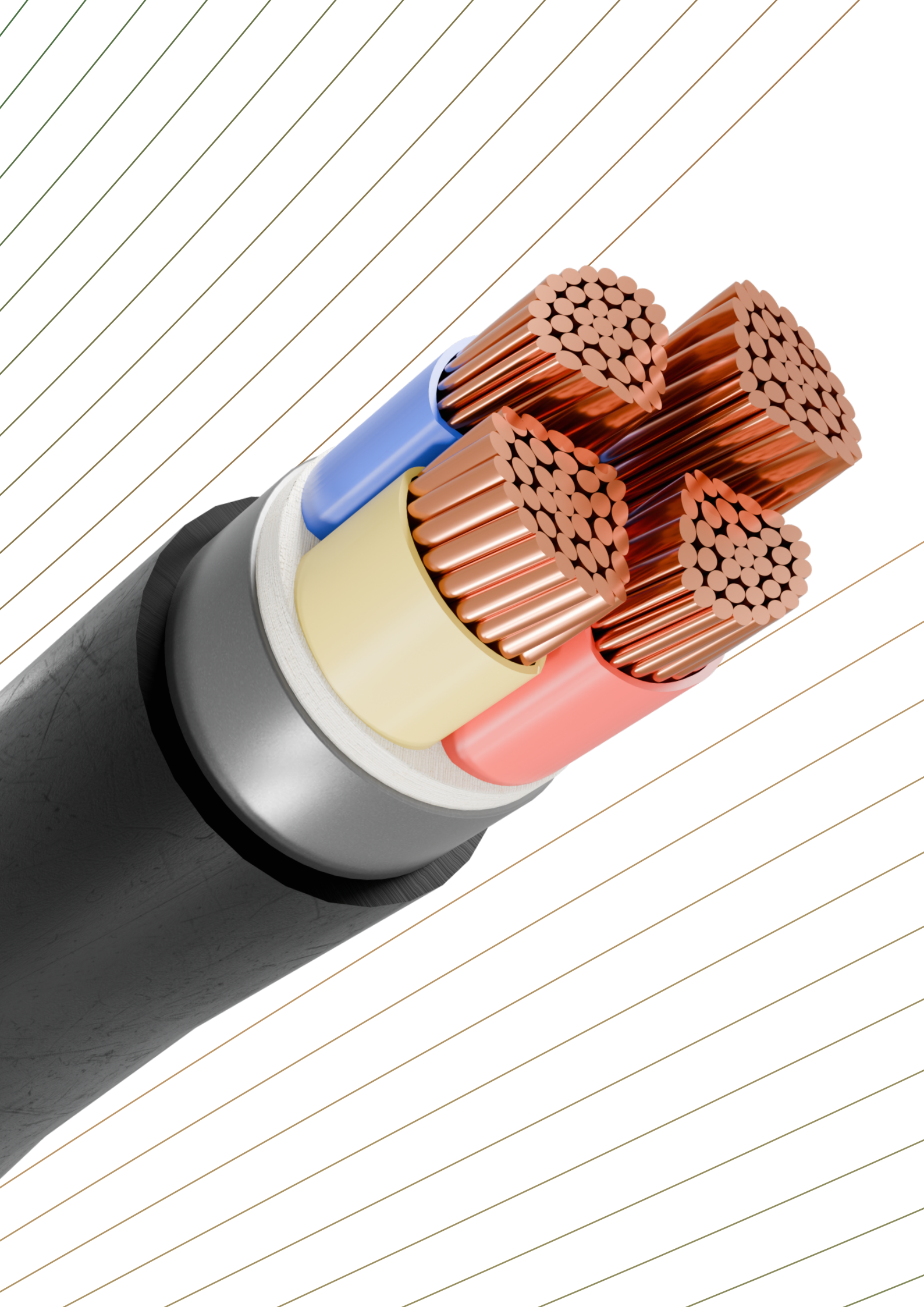





شركة الرواد لإنتاج الأسلاك والقابلات الكهربائية  
AL ROWAD COMPANY FOR PRODUCTION OF ELECTRIC CABLES

إحدى شركات  
Subsidiary of



مجموعة كابلات الرياض  
Riyadh Cables Group



[www.alrowadcable.com](http://www.alrowadcable.com)

[in alrowadcables-iraq](https://www.linkedin.com/company/alrowadcables-iraq) [X alrowadcablesec](https://www.x.com/alrowadcablesec) [f Al-rowad-cables-company](https://www.facebook.com/Al-rowad-cables-company)

Phone: + +964 772 843 5656 | +964 780 444 2288  
sales@alrowadcable.com | info@alrowadcable.com

Awerij Area – Industrial Zone,  
Baghdad–Karbala Road – Baghdad – Iraq